

# FJDynamics FV2000 Automatic Lawn Mowing Robot User Manual(EN)

FJDynamics FV2000 Automatic Lawn Mowing Robot User Manual (V1.0.4)

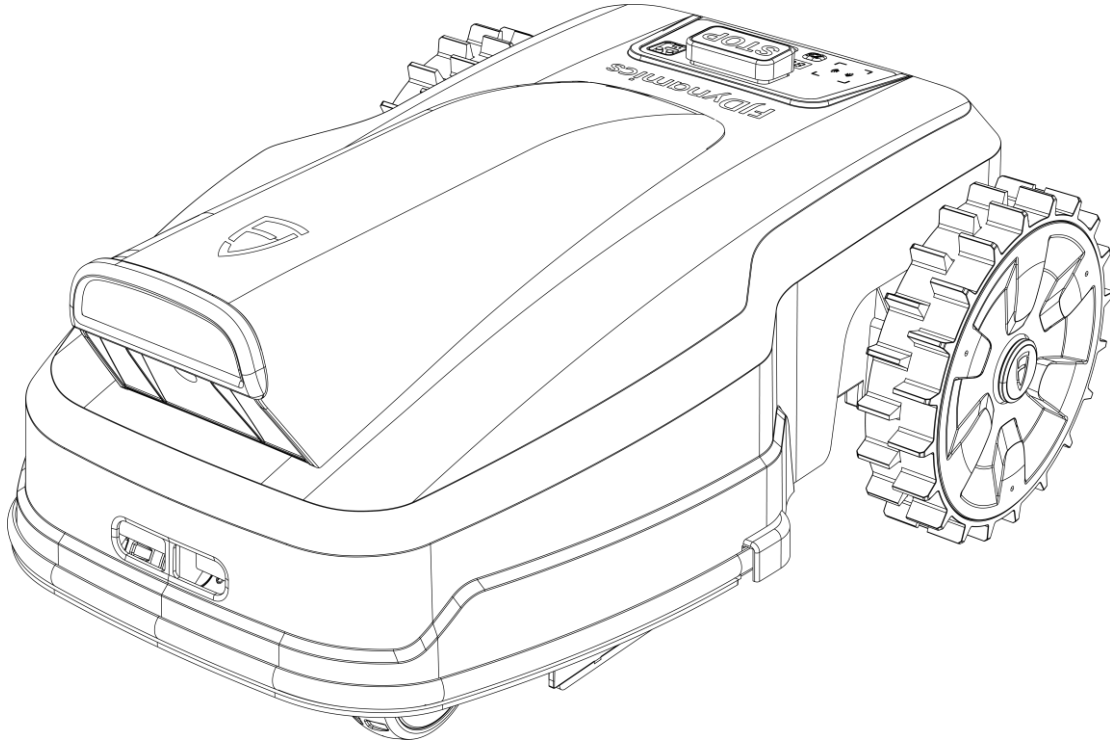

## Copyright Page

### Copyright Notice

Copyright © 2025 FJDynamics. All rights reserved.

### No Unlawful Use Permitted

No part of this manual may be reproduced, copied, distributed, transmitted, modified, translated, or otherwise exploited in any form or by any means, whether electronic, mechanical, photocopying, recording, or otherwise, without the prior written permission of FJDynamics.

### Disclaimer

The information contained in this manual is for informational purposes only and is subject to change without notice. FJDynamics makes no representations or warranties, express or implied, regarding the completeness or accuracy of the information contained in this manual. FJDynamics shall not be liable for any damages arising from the use of this manual.

### Updates

This manual is subject to change without notice. FJDynamics reserves the right to update the contents of this manual at any time without providing any prior notice or updates.

## Trademarks

FJDynamics and the FJDynamics logo are trademarks of FJDynamics. All other trademarks mentioned in this manual are the property of their respective owners.

## Contact Information

For more information about FJDynamics or its products, please visit our website at <https://www.fjdynamics.com/>.

## Preface

- How to Use the Manual: Instructions on how to navigate and use the manual effectively.

### Legend

 Warning

 Important

 Hints and Tips

 Reference

# 1. Safety Information

## 1.1 Safety Definitions

Warnings, cautions, and notes are used to highlight particularly important parts of the manual.

- **WARNING:** Indicates a risk of injury or death for the operator or bystanders if the instructions in the manual are not followed.
- **CAUTION:** Indicates a risk of damage to the product, other materials, or the adjacent area if the instructions in the manual are not followed.
- **Note:** Provides additional information that is necessary in a given situation.

## 1.2 General Safety Instructions

**WARNING:** Read the following warning instructions carefully before using the product.

**Read the Operator's Manual:** Ensure you understand the instructions before using the product. Keep the manual for future reference.

**Supervision and Instruction:** This appliance is not intended for use by children or persons with reduced physical, sensory, or mental capabilities, or lack of experience and knowledge, unless they have been given supervision or instruction concerning the use of the appliance by a person responsible for their safety. EU requirements allow this appliance to be used by children aged from 8 years and above and persons with reduced physical, sensory, or mental capabilities or lack of experience and knowledge, if they have been given supervision or instruction concerning the use of the appliance in a safe way and understand the hazards involved. Children shall not play with the appliance. Cleaning and user maintenance shall not be done by children without supervision.

**Operator Responsibilities:** The operator assumes full responsibility for all accidents or hazards that occur to people or property while using this equipment. This responsibility includes proper installation, safe operation, and maintenance of all safety features. The operator must ensure all additional users are properly trained in safety procedures and must maintain constant supervision of the work area when the equipment is in use.

## **1.2.1 Work Area Safety**

**WARNING:** Failure to follow proper safety procedures may result in injury or damage to property.

When operating in public areas, warning signs must be prominently displayed at all entry points to the work area. Each sign must clearly state: "Warning! Robotic lawn mower working! Keep away and supervise children and pets." These signs must remain clearly visible throughout the operation and should be removed when the mower is not in use.

The work area must be completely cleared of people, especially children, and all pets before operation begins. No one should enter the work area while the mower is operating. All toys, recreational equipment, garden tools, and debris must be removed from the area before starting the mower.

## **1.2.2 Equipment Safety**

The safe operation of this equipment depends on using only FJDynamics-recommended components and original FJDynamics batteries. The use of unauthorized parts may compromise safety features and void warranty protection. All safety features and warning labels must be maintained in good condition and replaced if damaged or illegible.

Power supply cables require special attention for safe operation. All cables must be routed outside the mowing area to prevent damage. The installation must include an appropriate Residual-Current Device (RCD) for electrical safety. Operators must inspect cables regularly for signs of wear or damage. If any cable becomes damaged during operation, immediately disconnect it from the power outlet and contact authorized service personnel for replacement. A damaged or worn cable presents a serious electrical hazard and must never be used.

## **1.2.3 Operational Safety**

The mower must be immediately powered off if any abnormal vibration occurs or if damage is detected. In the event of an accident or injury, seek immediate medical attention. Before performing any maintenance, clearing blockages, or examining the product, the mower must be completely powered off and all moving parts must come to a complete stop.

Never touch the blade disc or other moving parts until they have completely stopped moving. When maintenance is required, particularly when changing blades, proper protective gloves must be worn and appropriate tools must be used. This ensures both operator safety and prevents damage to the equipment.

## **1.2.4 Maintenance**

**WARNING:** Always power off the product before maintenance.

Regular maintenance inspections must be performed weekly. This includes checking blade conditions, verifying safety features are functioning properly, and ensuring warning signs remain visible and legible. The emergency stop function should be tested before each use.

Indoor storage is required when the mower is not in use. The storage area must be inaccessible to children, and the mower must be thoroughly cleaned before storage. All power connections should be disconnected during long-term storage.

## **1.2.5 Charging Station Safety**

The Charging Station provided with your mower is specifically designed for this model. No other

charging methods should be used. The station must be installed in a location that meets all clearance requirements and must be kept free of debris. During thunderstorms, disconnect all power and wiring from the Charging Station to protect the electrical components. After the storm passes, reconnect all wires carefully, ensuring proper connections.

## 1.2.6 Battery Safety

**WARNING:** The Charging Station provided with your mower is specifically designed for this model. No other charging methods should be used. The station must be installed in a location that meets all clearance requirements and must be kept free of debris. During thunderstorms, disconnect all power and wiring from the Charging Station to protect the electrical components. After the storm passes, reconnect all wires carefully, ensuring proper connections.

**Original Batteries:** Use only original batteries recommended by FJDynamics. Product safety cannot be guaranteed with non-original batteries.

The mower must only be charged using the included Charging Station. In the event of battery electrolyte leakage, immediately flush the affected area with water or an appropriate neutralizing agent. If any corrosive liquid contacts your eyes, seek immediate medical attention.

### 1.2.6.1 Maintenance and Storage

Indoor storage is required when the mower is not in use. The storage area must be inaccessible to children, and the mower must be thoroughly cleaned before storage. All power connections should be disconnected during long-term storage.

## 2. Product introduction

### 2.1 Introduction

Small lawn mowing robots can effectively reduce the maintenance manpower of residential grassland, reduce the cost of greening services, promote the healthy growth of grassland, and are an ideal intelligent product for home lawns. Fengjiang intelligent small lawn mowing robot adopts automatic random mowing and specific task mowing modes, based on various navigation and planning modes such as vision, LiDAR, and GNSS, and is suitable for lawn mowing operations in various complex terrains.

Fengjiang intelligent small lawn mowing robot, paired with a self-developed mobile APP, does not require on-site technical support from the manufacturer. Users can build lawn mowing maps and plan paths by themselves, allowing the lawn mower to automatically perform various mowing tasks and automatically return to the charging pile for charging. Users can control and view the mowing status and progress in real-time on the APP.

The main users are individuals who have a global demand for courtyard lawn maintenance, want to improve maintenance efficiency, reduce labor costs, and need to remotely monitor outdoor conditions.

### 2.2 Main components

#### 2.2.1 Lawn mower

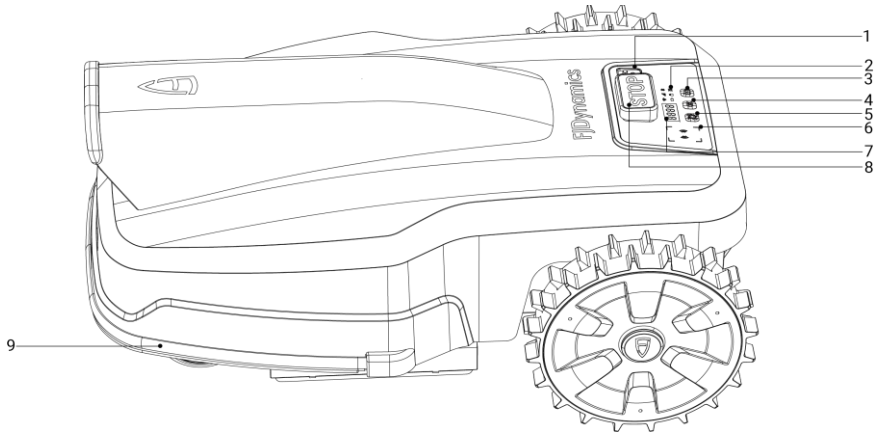

(Instructions - Main Components - Lawn Mower - Front View - Missing Number)

| Number | Component name   |
|--------|--|
| 1      | Raindrop sensor  |
| 2      | Knife indicator light  |
| 3      | Recharge button  |
| 4      | Confirm button   |
| 5      | Mowing button  |
| 6      | Digital display screen   |
| 7      | Indicator light area<br>(including the following<br>6 indicator lights,<br>which can reduce the<br>number of labels) |
|        | Wi-Fi indicator light  |
|        | RTK signal indicator<br>light  |
|        | Bluetooth indicator<br>light   |
|        | Power indicator  |
|        | Lock indicator light   |
|        | Knife indicator light  |

|   |                       |
|---|-----------------------|
| 8 | Emergency stop button |
| 9 | Collision bar         |

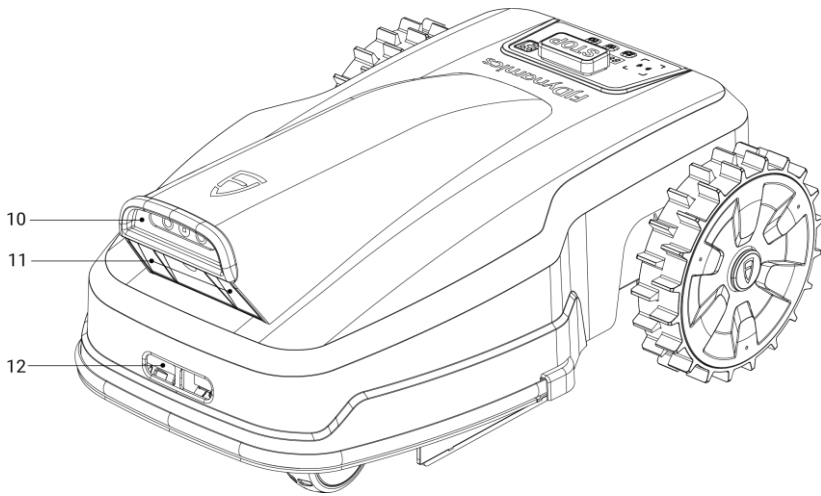

(Instructions - Main Components - Lawn Mower - Bottom View - Missing Number)

|    |                  |
|----|------------------|
| 10 | Monocular camera |
| 11 | Searchlight      |
| 12 | Charging port    |

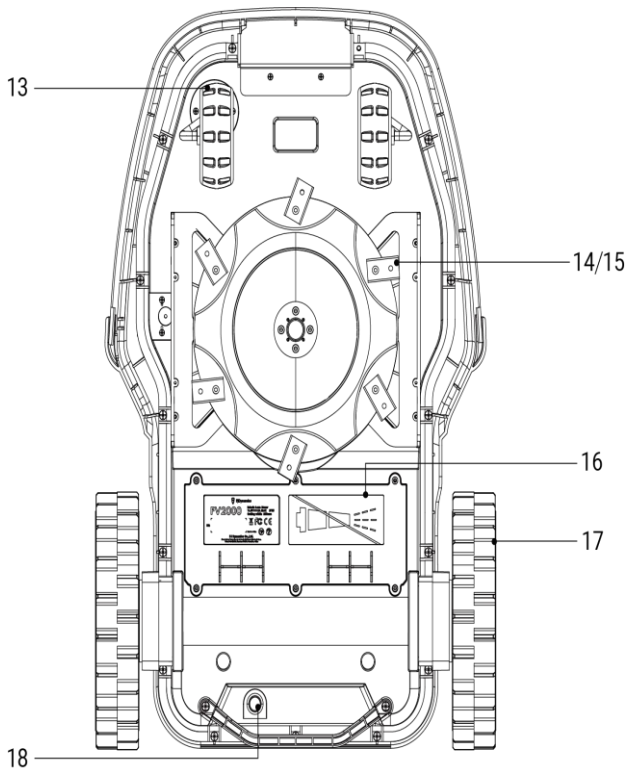

|    |              |
|----|--------------|
| 13 | Power switch |
|----|--------------|

|    |                     |
|----|---------------------|
| 14 | Universal wheel     |
| 15 | Driving wheel       |
| 16 | Cut disk            |
| 17 | Cutting knife       |
| 18 | Battery compartment |

## 2.2.2 Charging pile

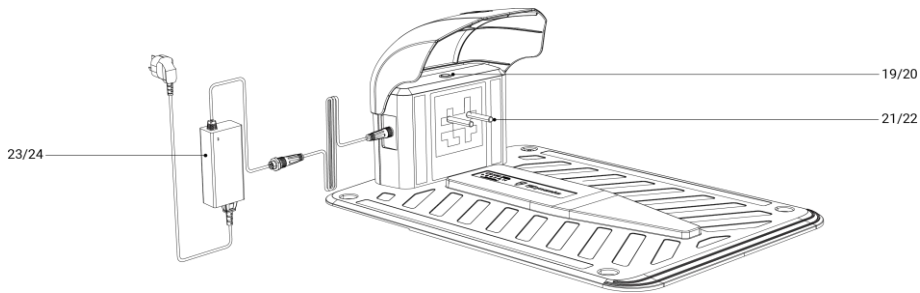

| Number | Component name                       |
|--------|--------------------------------------|
| 19     | Top button + status indicator        |
| 20     | Garage                               |
| 21     | Charging interface                   |
| 22     | Charging electrode                   |
| 23     | Power Supply                         |
| 24     | Power Adapter (Please place indoors) |

## 2.3 Specification parameters

| Specs    |                 | FJD FV2000                             |
|----------|-----------------|--|
| Capacity | Max mowing size | 2000 m <sup>2</sup> (0.5 acre)         |
|          | Boundary type   | Virtual boundaries (No perimeter wire) |
|          | Net weight      | 13.156kg                               |

|                                     |  |  |
|-------------------------------------|--|--|
|                                     | <b>Dimension</b>   | 631mm*444mm*290mm<br>17.4in*11.42in<br>24.8448         |
|                                     | <b>Max climbing ability</b>  | 33° (65%)  |
|                                     | <b>Waterproof level (mower, charging station, RTK reference station)</b> | IPX5, IP65, IP67                                       |
| <b>Positioning &amp; Navigation</b> | <b>Industrial RTK &amp; enhanced vision</b>                              | Supported  |
|                                     | <b>Radio RTK mode &amp; network RTK mode</b>                             | Supported  |
|                                     | <b>User interface</b>  | Keyboard & APP control                                 |
|                                     | <b>Firmware update</b>   | APP update through OTA                                 |
|                                     | <b>Connectivity</b>  | Wi-Fi & Bluetooth                                      |
| <b>Cutting System</b>               | <b>Cutting width</b>   | 255mm 10in   |
|                                     | <b>Cutting height range</b>  | 10~50mm 0.4~2in  |
|                                     | <b>Mowing speed range</b>  | 0.3~0.5m/s   |
|                                     | <b>Blade speed range</b>   | high, middle, and low                                  |
|                                     | <b>Blade type</b>  | 6 pivoting stainless steel blades                      |
|                                     | <b>Cutting mode</b>  | parallel stripes with a specific angle                 |
| <b>Product Safety</b>               | <b>Object detection &amp; avoidance system</b>                           | RGB camera & physical bumper                           |
|                                     | <b>Lift sensor</b>   | Yes  |
|                                     | <b>Security System</b>   | PIN access, alarm, charging station pairing, GPS theft |

|                    |                             |                     |
|--------------------|-----------------------------|---------------------|
|                    |                             | tracking            |
|                    | Tilt sensor                 | Yes                 |
| Battery & Charging | Single battery capacity     | 95Wh                |
|                    | Battery type                | Lithium-ion battery |
|                    | Charging mode               | Automatic & manual  |
|                    | Auto-recharging             | Yes                 |
|                    | Mowing time per full charge | 90 min              |
|                    | Charging time               | 60 min              |

### 3. Preparation before use

#### 3.1 List of goods

**Charging Station Kit**



Power Supply Cable
Extension Cable (10m)
Power Adapter

**Mower Accessory Kit**

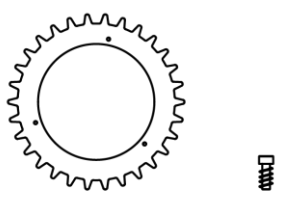

Skid Plate\*2
M4 Screw\*6

**Universal Tool Kit**



Hex Wrench (Large)
Hex Wrench (Small)
M8 Wrench
Screwdriver
M8 Expansion Screw\*3
Spare Blade\*6
Skid Plate Screw\*6
M6 Screw\*3
Screw\*4

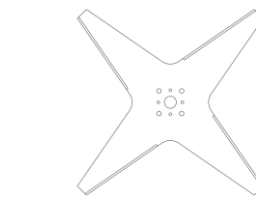

Star blade \*1

## 4. Deploy and install

If you have a network RTK service account based on Ntrip, you can use the network RTK positioning scheme.

### 4.1 Deploy lawn mowers and charging stations

1. Choose a flat and horizontal place to place the charging station. Leave a free horizontal area with a radius of no less than 2 meters in front of the charging station, without hills, slopes, depressions, potholes or obstacles.
  - a. Ensure that the grass under the charging station board is not higher than 5cm (about 2 inches).

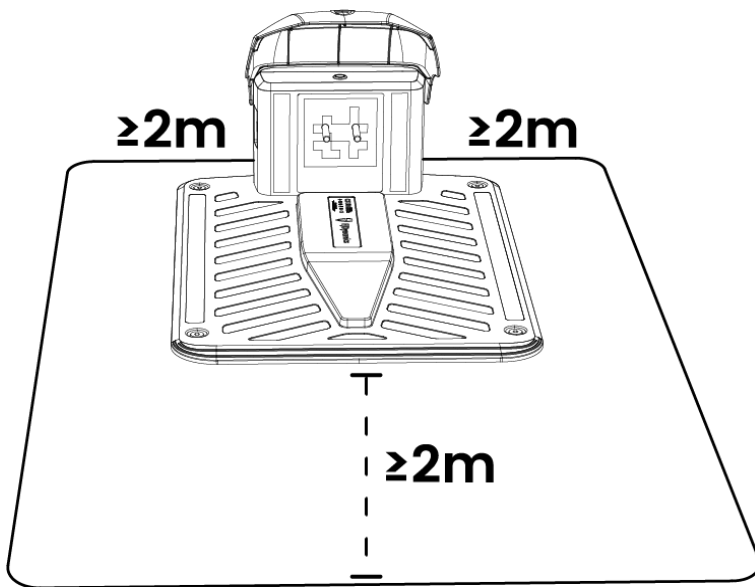

2. Fix the charging station and garage to the ground with bolts.

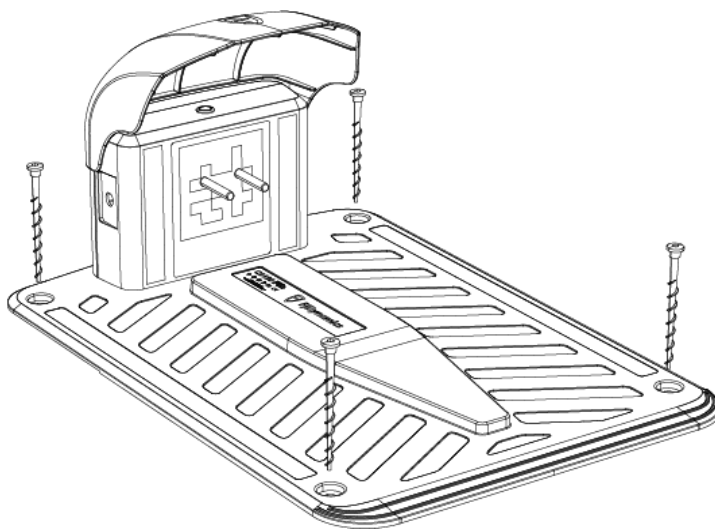

3. Connect the power adapter (note: must be placed indoors), 10-meter extension cord and power cord, and plug them into the power socket.

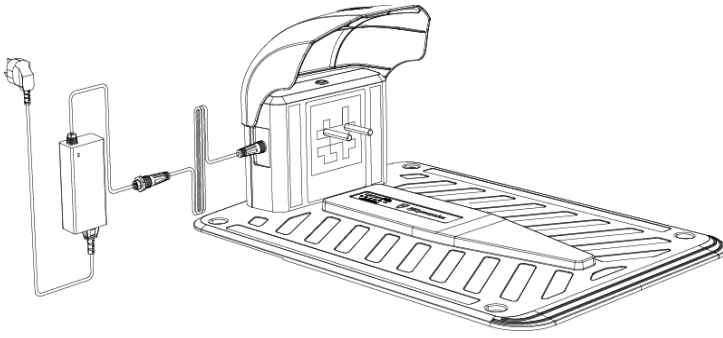

## 4.2 Docking lawn mowing robot

After the charging pile have been deployed, remove the lawn mowing robot and connect it to the charging pile through the following methods:

- Press the button on the charging pile, confirm that the indicator light turns green and flashes quickly, and enter the direct charging mode.
- Connect the lawn mowing robot to the charging pile as shown in the picture and wait for it to power on.
- After confirming that the lawn mower is powered on, turn on the lawn mowing robot switch.

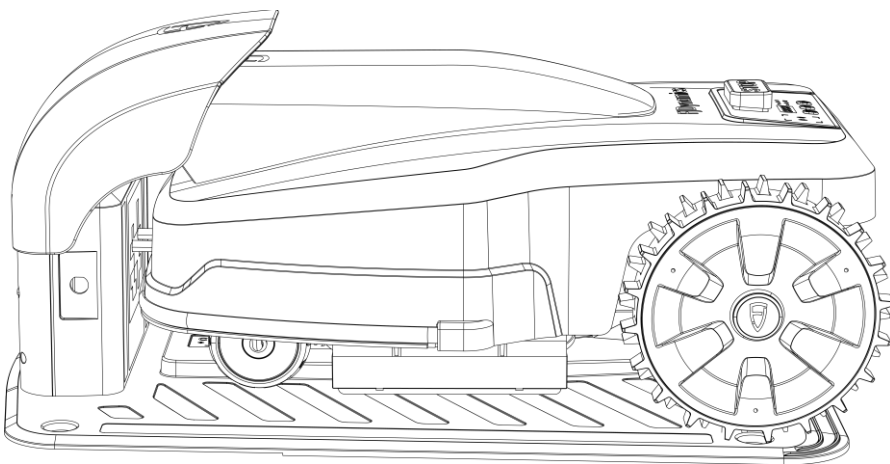

## 5. Instructions for use

### 5.1 Preparation work

- Read and understand safety tips before use.
- Charging piles have been deployed.
- Make sure the mowing robot has been connected to the charging pile and charged. If not, refer to the connection with the mowing robot.
- Make sure there is a good and available Wi-Fi or mobile hotspot signal nearby.
- Make sure your phone's Bluetooth function is turned on.

### 5.2 Download the lawn mowing robot APP.

Fengjiang intelligent lawn mowing robot is designed to be used with an APP. Please download the APP

first. You can obtain it by scanning the QR code below or searching for FJD Landscaping in the Android | IOS store.



## 5.3 Register a Fengjiang Smart account and log in

If you already have an account with Fengjiang Intelligence, please refer to login only.

### 5.3.1 Register and log in

After the app is downloaded, you can create an account according to the instructions below.

#### 5.3.1.1 Register with an email

1. Click Register Now.
2. Enter an email address.
3. Click the {Send} button, and a verification email will be sent to your email address (if not received, please check your spam folder).
4. Enter the verification code (the valid period of the verification code is 10 minutes, please click the {Send} button again to get a new verification email).
5. Set a password (the password needs to be between 8 and 22 characters, with at least lowercase letters and numbers).
6. Check User Agreement and Privacy Policy.
7. Click {Create account} to complete registration and log in.

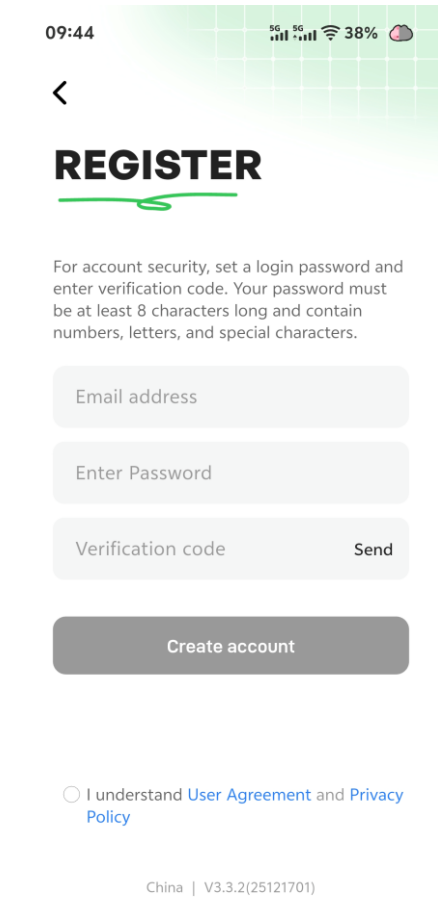

### 5.3.1.2 register with your phone number

Mobile phone number registration currently only supports Chinese mainland mobile phone numbers.

### 5.3.2 Log in only

You can directly enter "Email address+ password" or "Email address + verification code", check the User Agreement and Privacy Policy, and click {Log in} to enter the main interface of the system.

Click on the upper left corner of the login page to switch the APP language.

Password login

Login with verification code

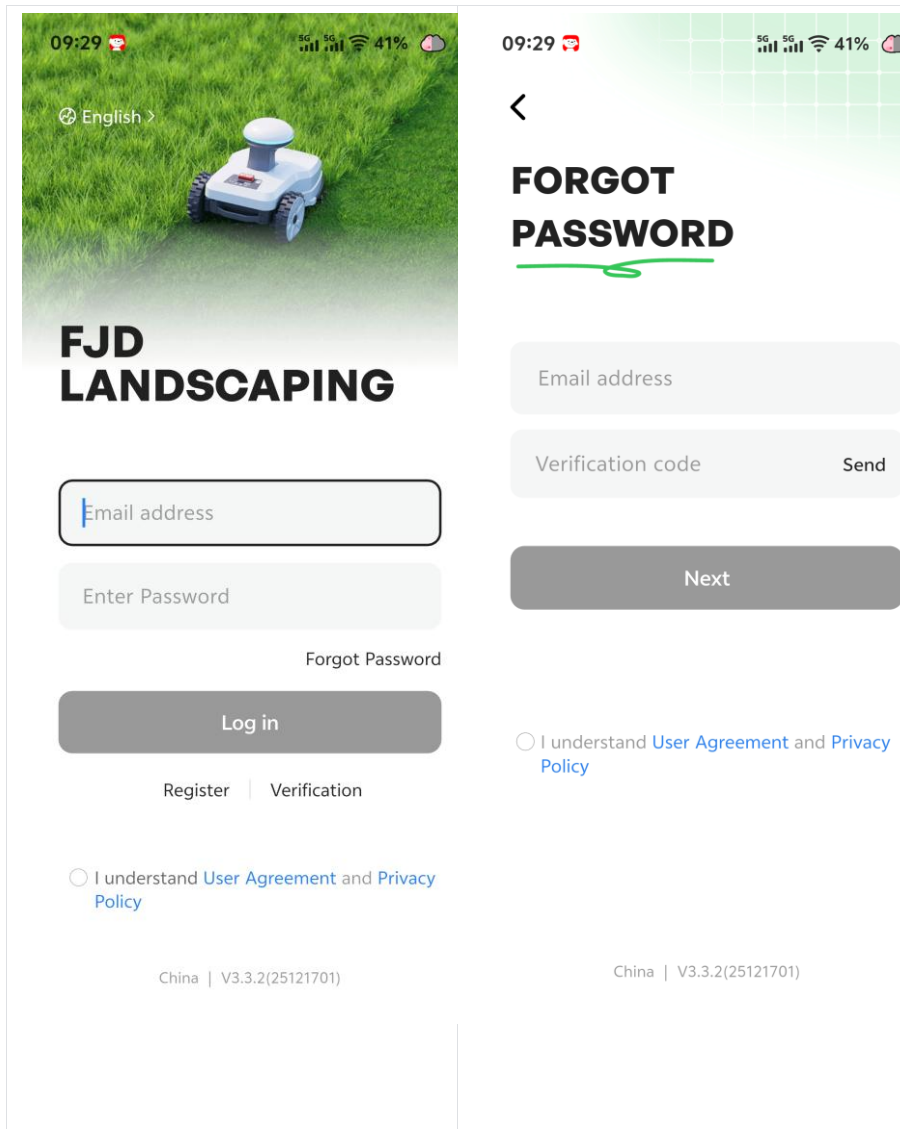

## 5.4 Lawn mowing robot deployment

### 5.4.1 Flow - Binding and Distribution

Note:

To ensure that the Bluetooth function is normal, please make sure that the phone has turned on the Bluetooth function and the distance between the phone and the lawn mowing robot is less than 3 meters.

1. Click {Add Device}
2. Select {FV2000}
3. Follow the instructions to complete the setting of the lawn mowing robot

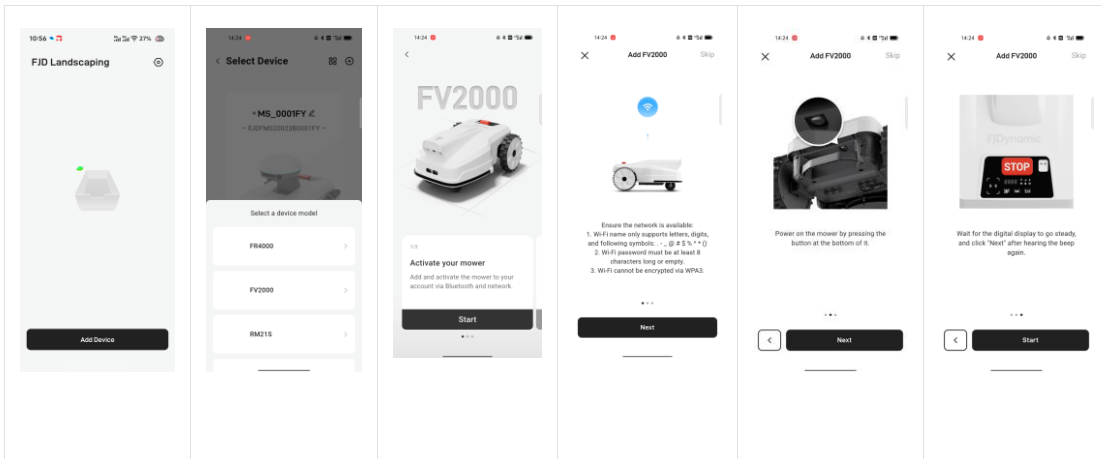

**Note:**

- FJDynamics lawn mowing robot only supports 2.4GHz Wi-Fi network. Connecting to 5G network will affect OTA function.
- If you are using a iOS device, the lawn mower can only choose to connect to the Wi-Fi that your mobile device is connected to. Please first connect your mobile device to Wi-Fi, and then connect the lawn mower to the same Wi-Fi.

When adding devices for the first time, guiding the phone to connect to the car via Bluetooth will start the network configuration process

- Select the Wi-Fi network to connect to
- Enter Wi-Fi password
- Click Join to complete network distribution and machine binding

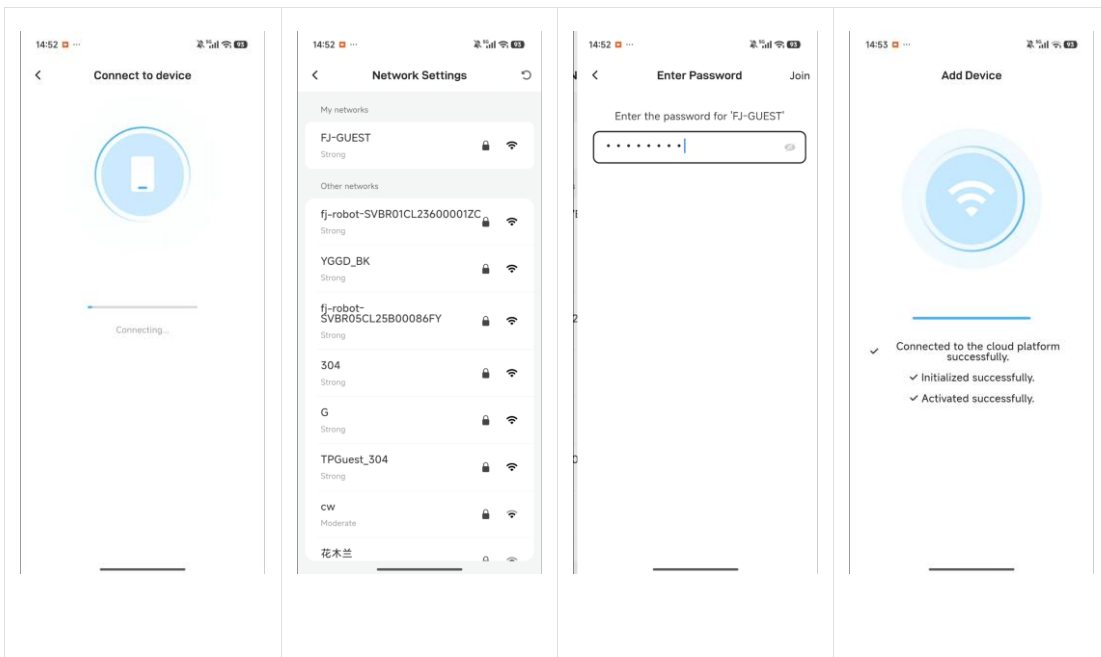

**5.4.2 Flow - Set Location Mode**

The positioning mode of the lawn mowing robot supports two solutions: Ntrip (network RTK) or Internal radio (local base station).

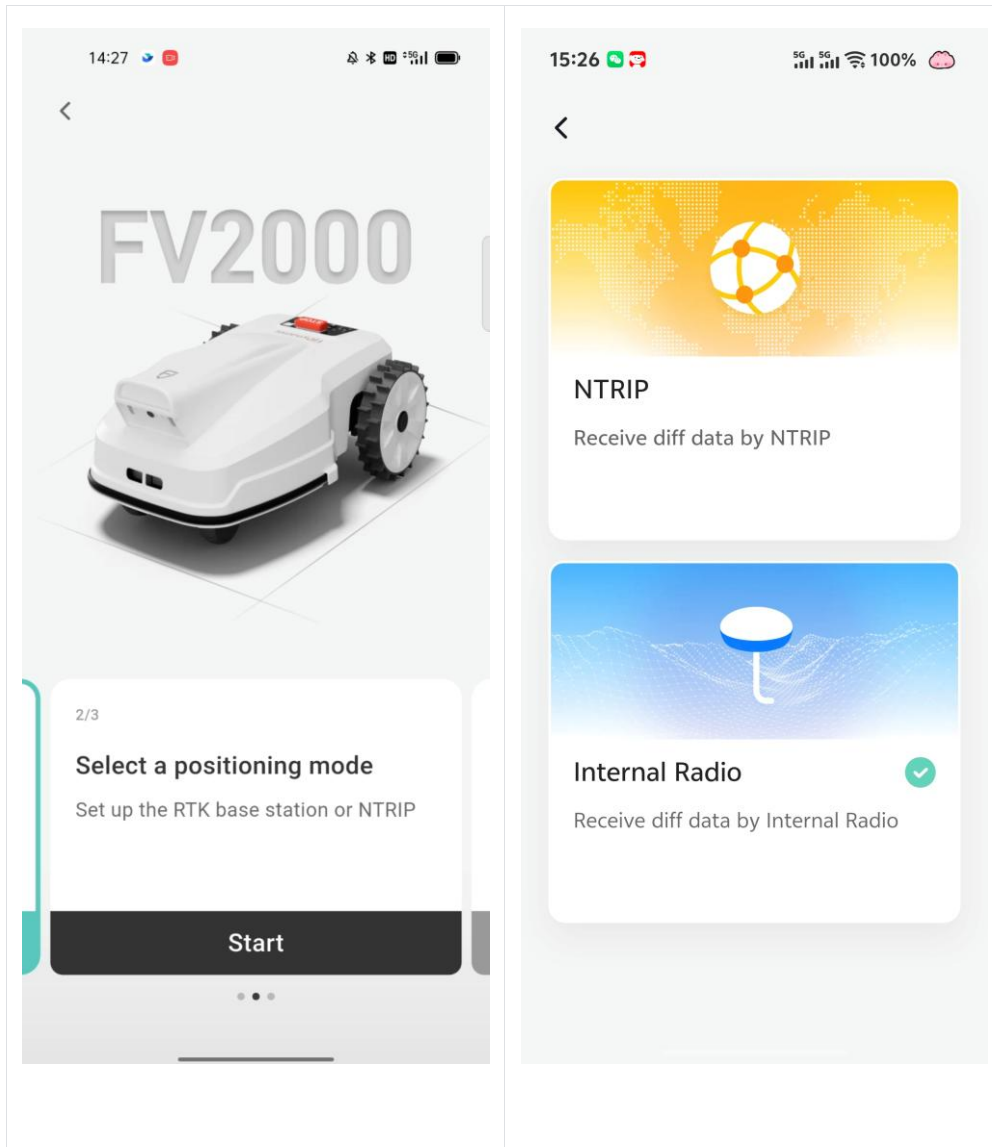

### 5.4.2.1 Ntrip mode

1. Select {Ntrip} in location mode.
2. Read the deployment instructions
3. Enter the required Ntrip network RTK configuration
4. Waiting for base station function deployment to complete

14:27

< NTRIP

Name Not null

IP Not null

Port Not null

Source Node Not null

Username Not null

Password Not null

Apply

### 5.4.3 Flow - Drawing

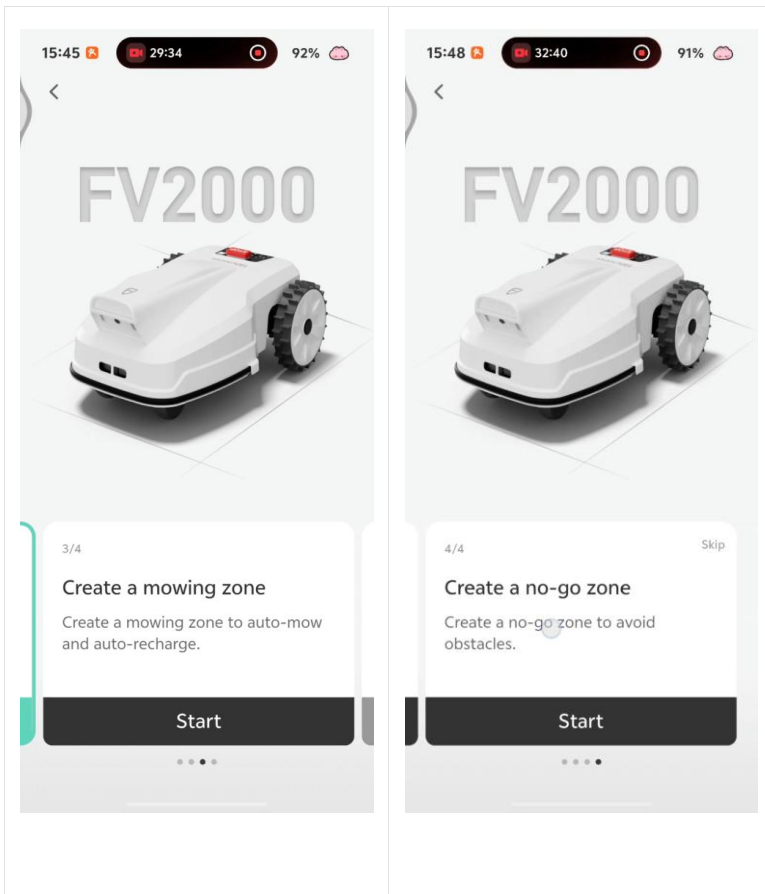

### 5.4.3.1 Notes before drawing

Before creating a map, there are the following precautions:

- Clean up debris, piles of fallen leaves, toys, wires, stones and other obstacles on the lawn before creating a map. Make sure there are no children or animals on the lawn.
- The lawn mower is in normal condition.
- It is still recommended that you leave a distance of 15cm when the remote mowing robot follows obstacles such as walls, fences, ditches, etc.
- During the mapping process, in order to ensure better Bluetooth connection and timely handling of on-site conditions, please follow the mowing robot and keep within 3m distance.
- Please do not draw intersecting routes.
- Ensure that the lawnmower has sufficient battery when mapping, and do not interrupt the Bluetooth connection between the remote control phone and the lawnmower.

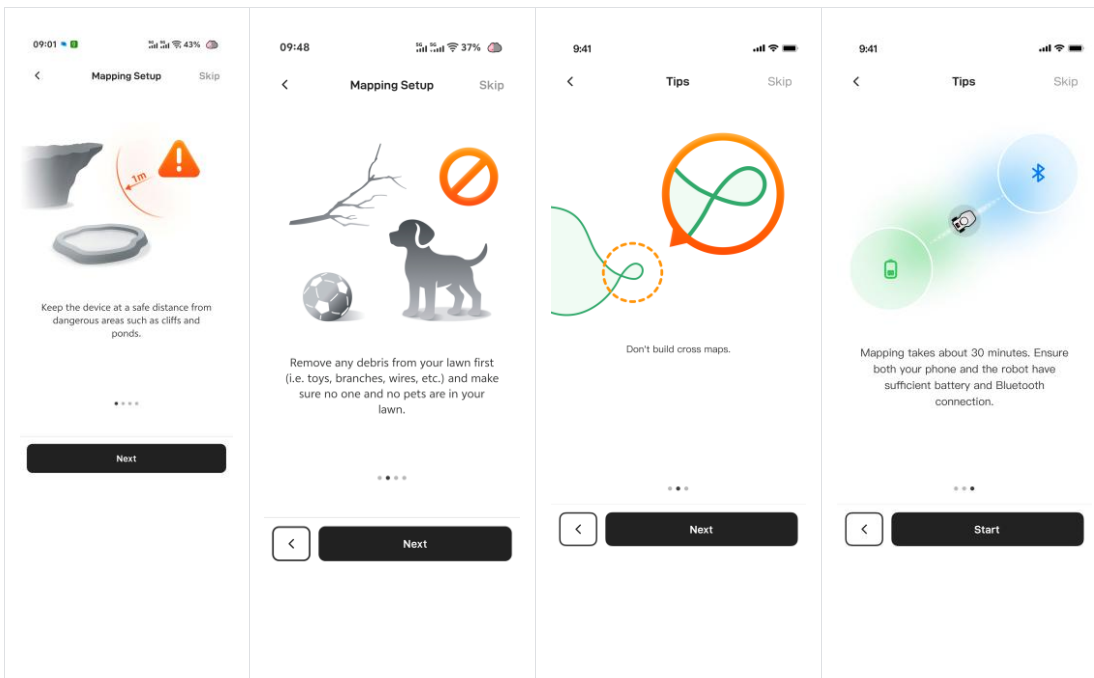

### 5.4.3.2 Construction work area

#### 5.4.3.2.1 Pillless mapping

1. Confirm that the lawn mowing robot has been turned on and the emergency stop button has not been pressed. It is recommended that the battery level be above 50%.
2. Click the {Start} button in the process, or click the {Create Now} button on the Facility Management page.

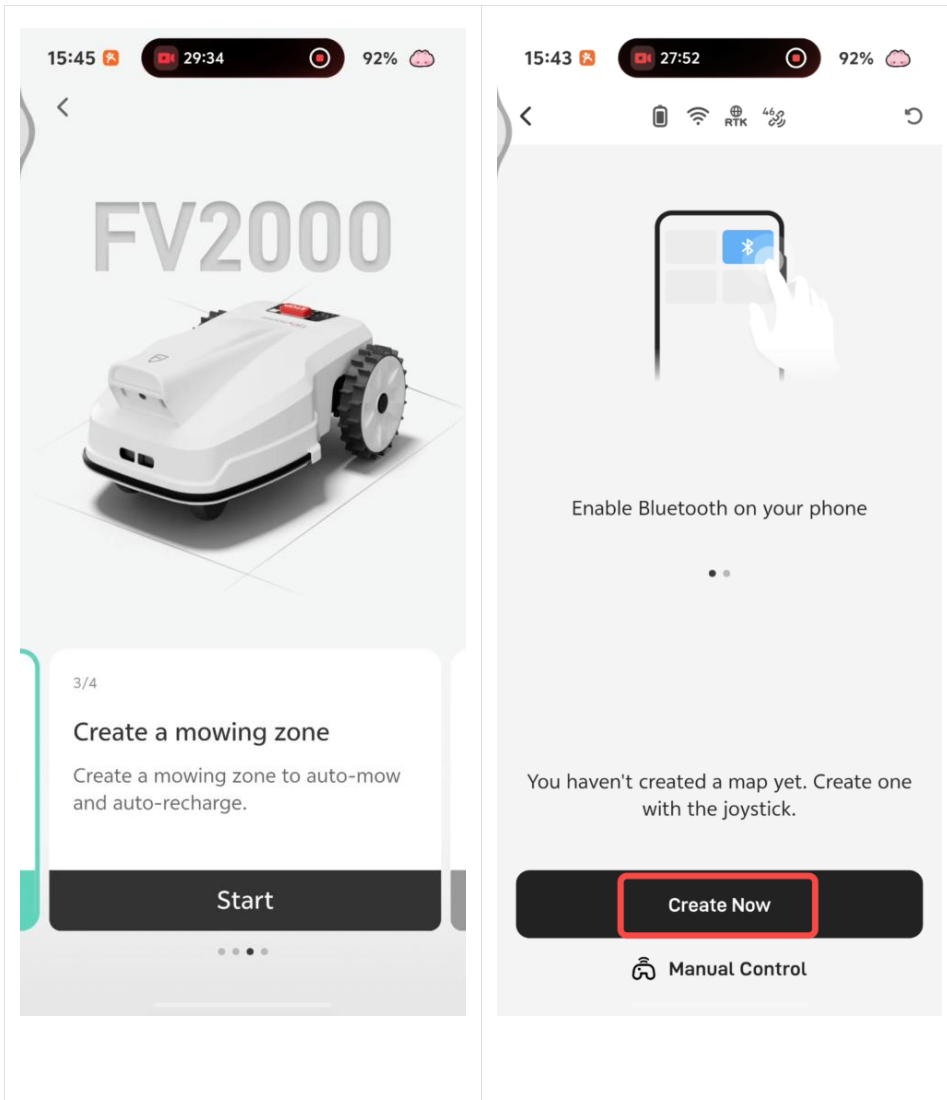

3. Click {Mowing Zone - Without Charging Station}.

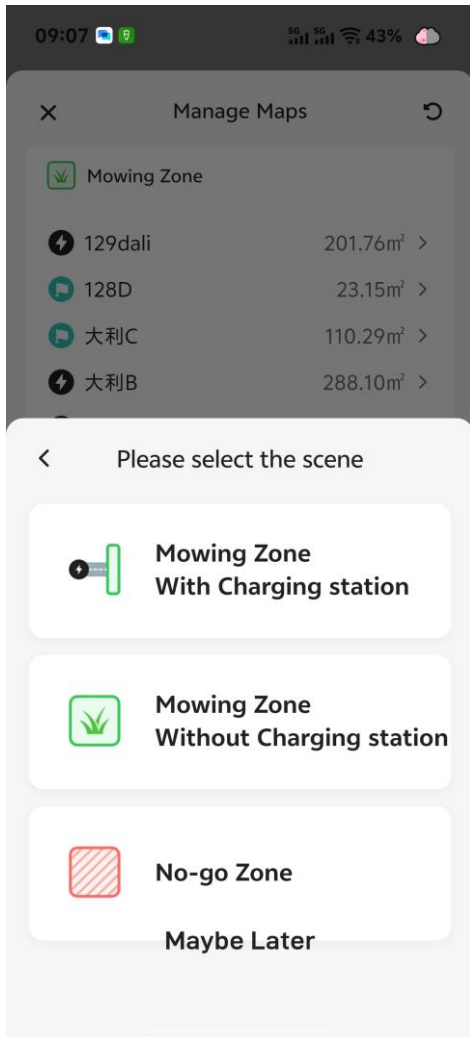

4. Click {Without Passage} to start drawing the workspace boundary directly at the current position of the lawn mower. {With Passage} mode is not yet open.

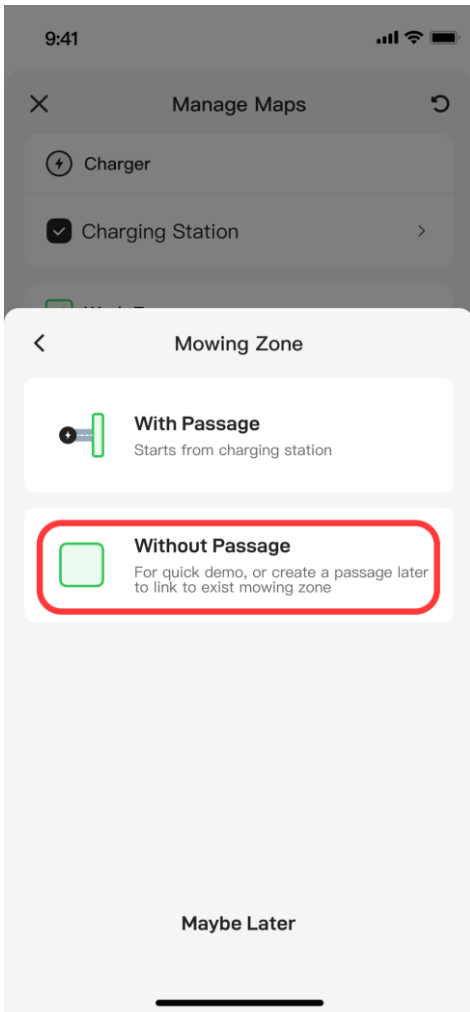

5. After confirmation, the lawn mowing robot will leave the charging pile on its own

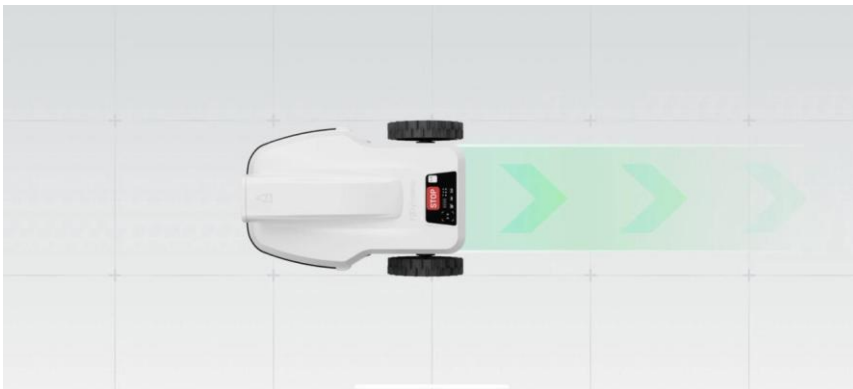

6. After the lawnmower stops, a connection line can be established through APP operation

#### 5.4.3.2.2 There is an RTK fixation solution at the charging pile

If the lawnmower has an RTK fixed solution at the charging pile, mapping will be performed through RTK.

Note:

If the charging pile you deploy is outside the expected working area, please refer to the charging pile external construction map.

If the charging pile you deploy is within the expected working area, please refer to

the built-in mapping of the charging pile.

If the charging pile has not been marked, the charging pile will be marked together during the first construction of the working area.

#### 5.4.3.2.2.1 Charging pile external mapping

1. Confirm that the lawn mowing robot has been turned on, is on the charging pile, and is working normally. The emergency stop button has not been pressed, and the recommended battery level is above 50%.
2. Click the {Start} button in the process, or click the {Create Now} button on the Facility Management page.

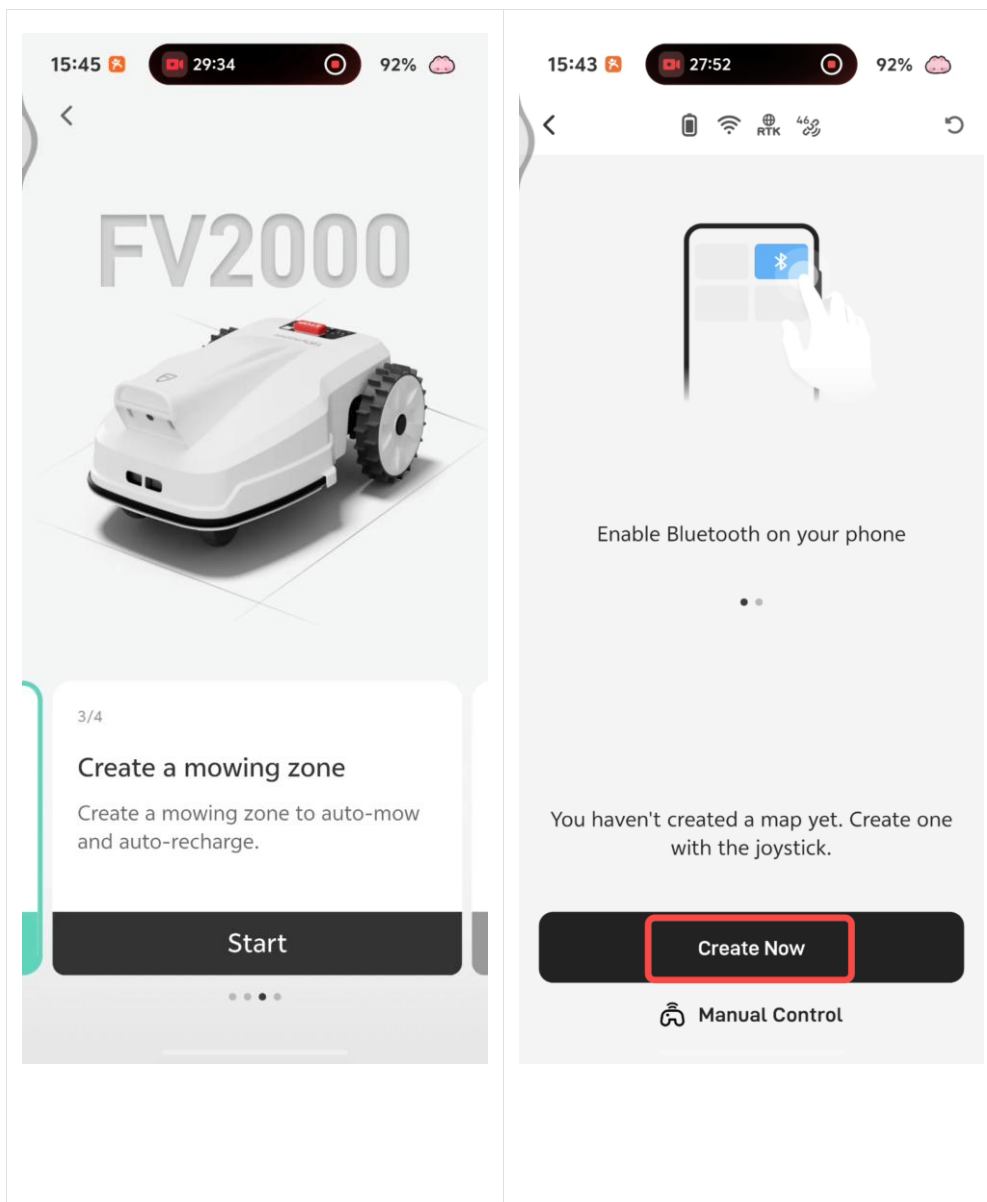

3. Click {Mowing Zone - With Charging Station}.

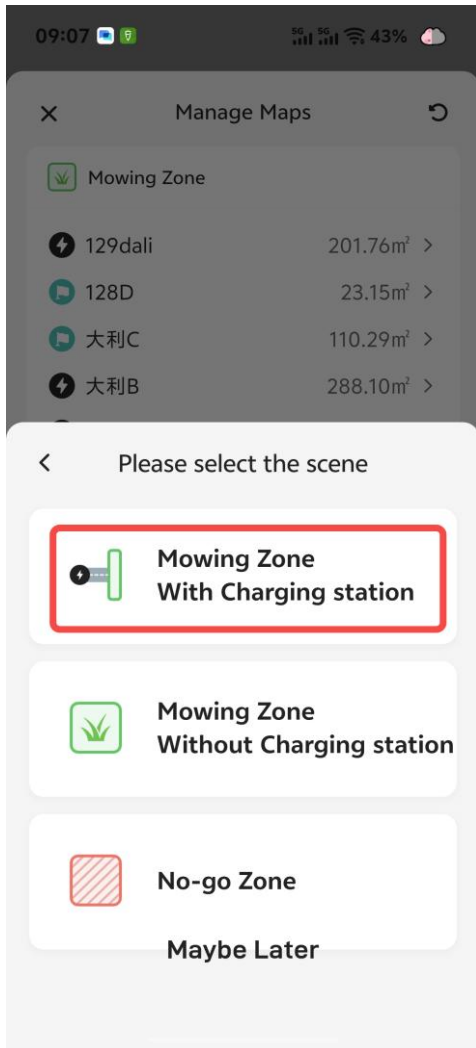

4. When establishing a corridor between the charging pile and the work area, you can choose {Smart Mapping} to directly use RTK positioning method

15:17

01:22

98%



## Mapping Setup



Mapping Tip: If your charging station is near obstructions (e.g., walls, houses, or trees), use Visual Assistance to guide the mower to an open area. Confirm the positioning is accurate before starting the mapping process.

Smart Mapping

5. After confirmation, the lawn mowing robot will leave the charging pile on its own



6. After the lawnmower stops, a connection line can be established through APP operation.
  - a. The connection line records the path of the lawn mowing robot from the charging pile to the work area. When it actually starts working, it will walk along this path. Please make sure that this path is a drivable path.

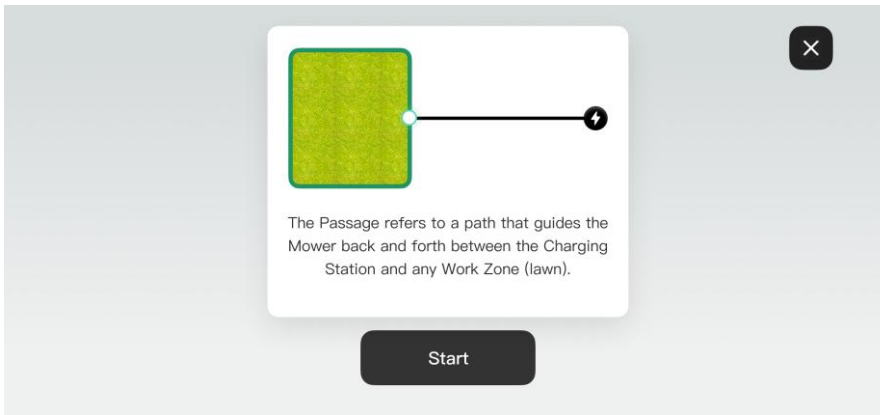

7. After clicking the {Start} button, operate the joystick to remotely control the lawn mowing robot to the edge of the expected work area.

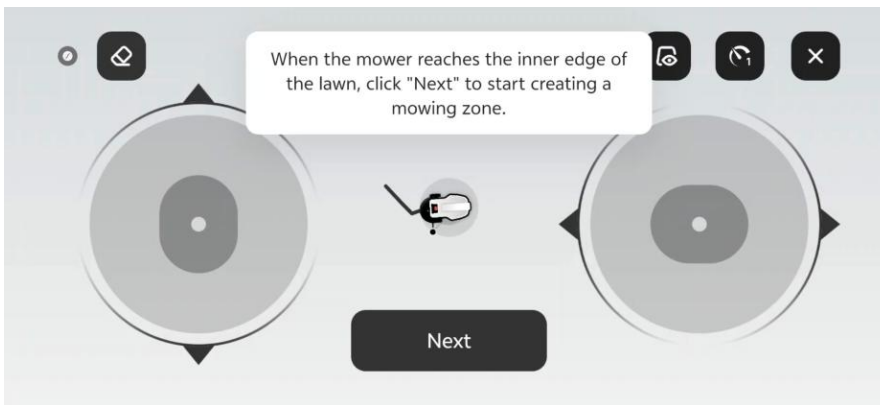

8. Click the {Next} button to save the cable and enter the process of establishing the mowing area.

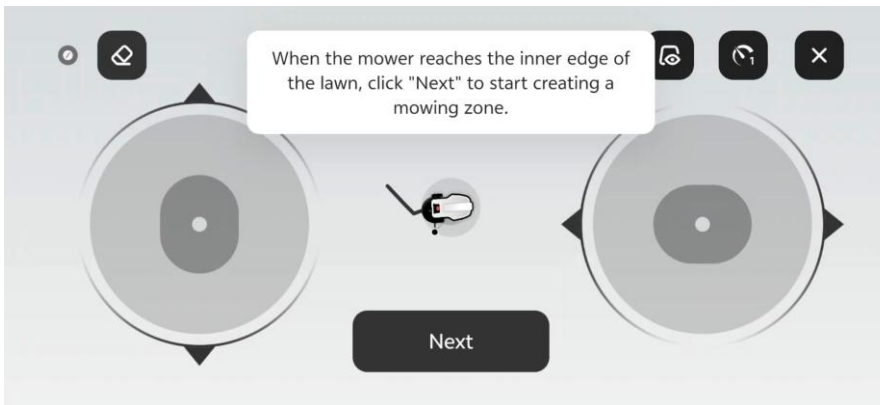

9. After the connection line is saved, the mowing area can be established through the APP operation.
  - a. After clicking the {Start} button, operate the joystick to remotely control the lawn mower robot to walk along the desired lawn edge to draw your lawn boundary.

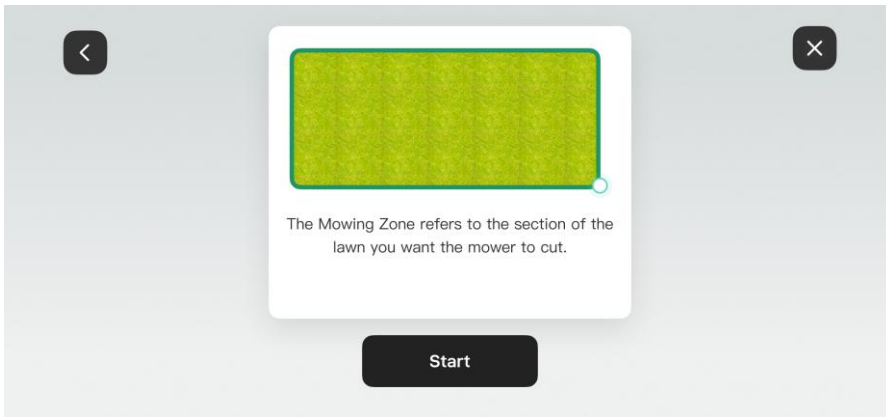

10. The solid line marks the boundary you have drawn, while the dashed line will help you return to the starting point.

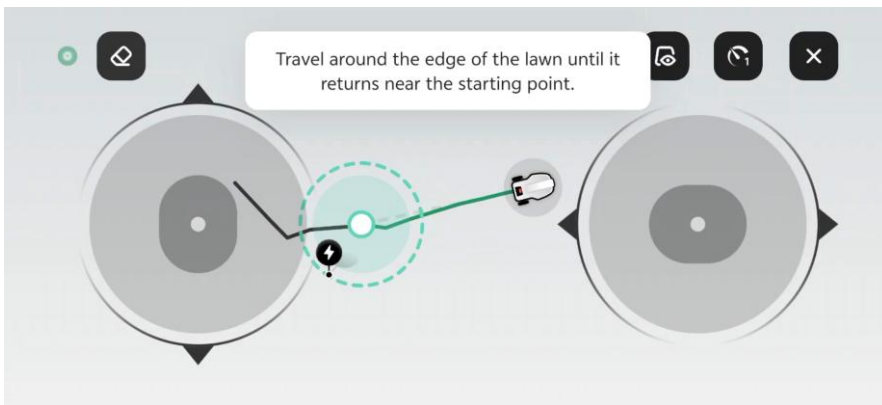

11. The mowing area will not be created until you control the mowing robot to return to the drawing starting point and click {Finish}.

12. If necessary, click the {erase button}, and the lawn mower robot will roll back along the already drawn path, erasing the boundary of the rolled back work area.

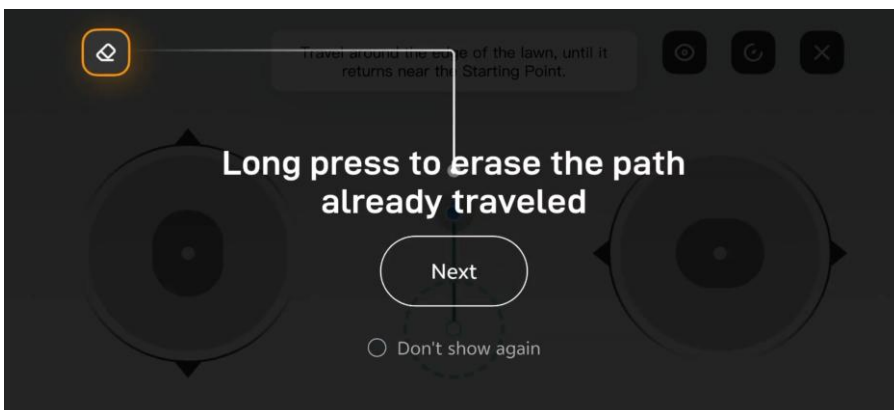

13. Control the mowing robot to the starting point and click the {Finish} button to save the work area.

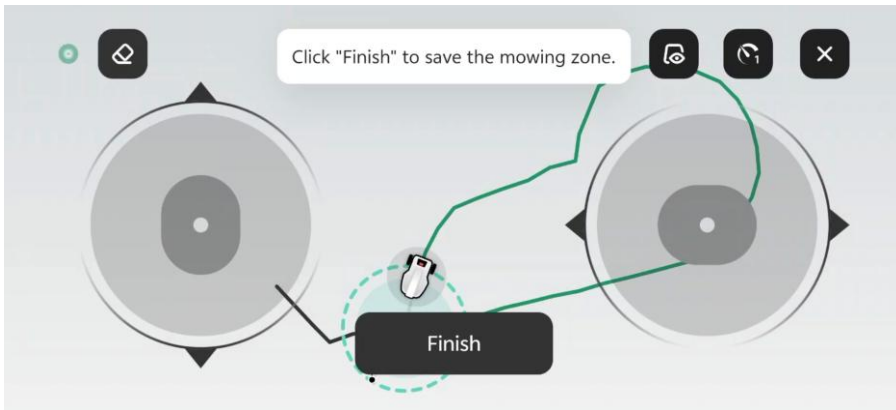

14. Name the work area.
15. Complete the mowing area mapping process

#### 5.4.3.2.2 Charging pile built-in mapping

1. Same as above 1: Make sure the lawn mowing robot is turned on, on the charging pile and working normally, with a fixed solution and no emergency stop button pressed. It is recommended that the battery level be above 50%.
2. Same as above 2: Click the {Start} button in the process, or click the {Create Now} button in the Facility Management page.
3. Same as above 3: Click {Mowing Zone - With Charging Station}.
4. The lawn mowing robot will automatically retreat from the pile.



5. After the lawnmower stops, the mowing area can be established through the APP.
  - a. After clicking the {Start} button, operate the joystick to remotely control the lawn mowing robot to draw your lawn boundary.

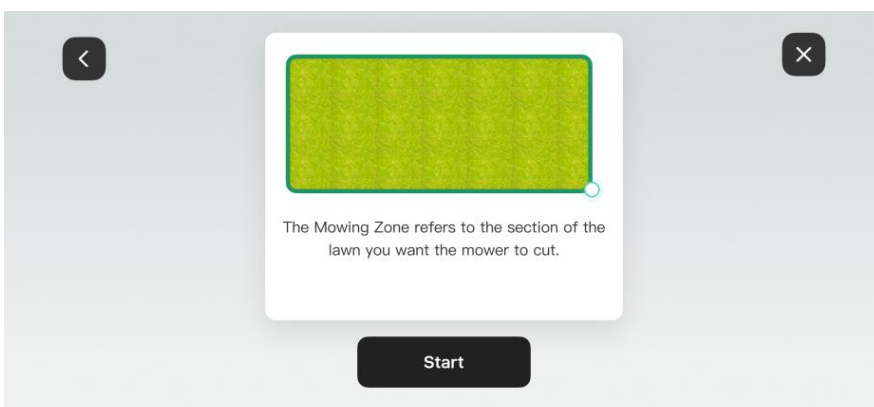

6. The solid line marks the boundary you have drawn, while the dashed line will help you return to the starting point.

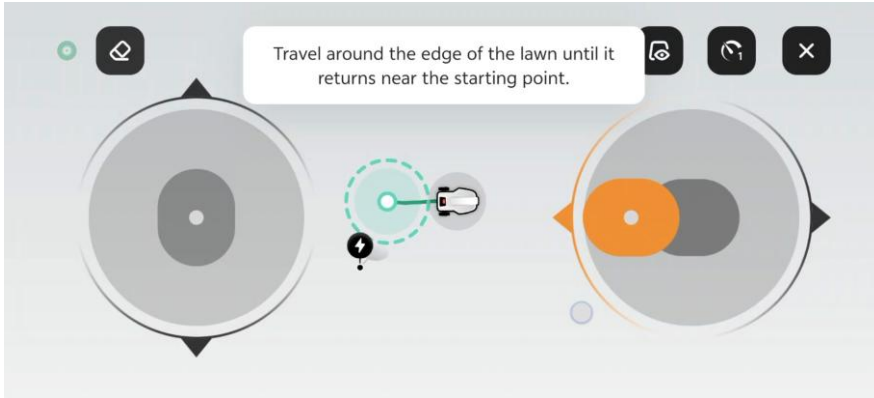

7. The lawn map will not be created until you control the lawn mower to return to the starting point.

8. If necessary, click the {erase button}, and the lawn mower robot will roll back along the already drawn path, erasing the boundary of the rolled back work area.

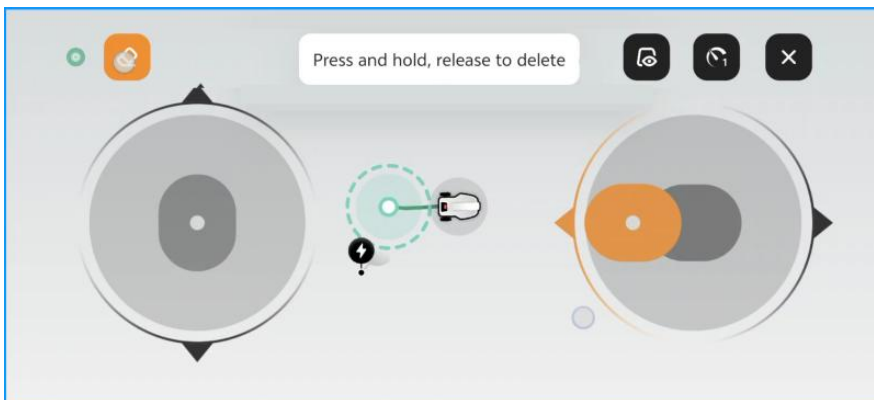

9. Control the mowing robot to the starting point and click the {Finish} button to save the work area.

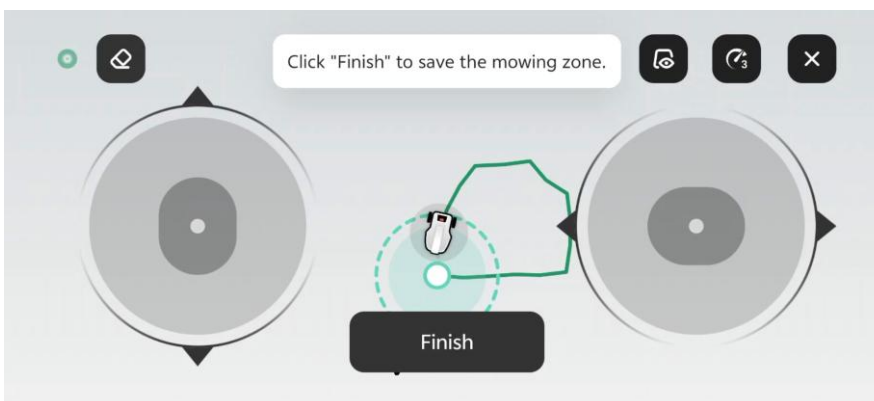

10. Name the work area.

11. Complete the mowing area area mapping process

### 5.4.3.2.3 No RTK fixation solution at the charging pile

If the lawn mower is blocked by eaves or other obstacles at the charging pile position, resulting in no RTK fixation solution, mapping will be performed through visual assistance.

1. Confirm that the lawn mowing robot has been turned on, is on the charging pile, and is working normally. The emergency stop button has not been pressed, and the recommended battery level is above 50%.

2. Click the {Start} button in the process, or click the {Create Now} button on the Facility Management page.

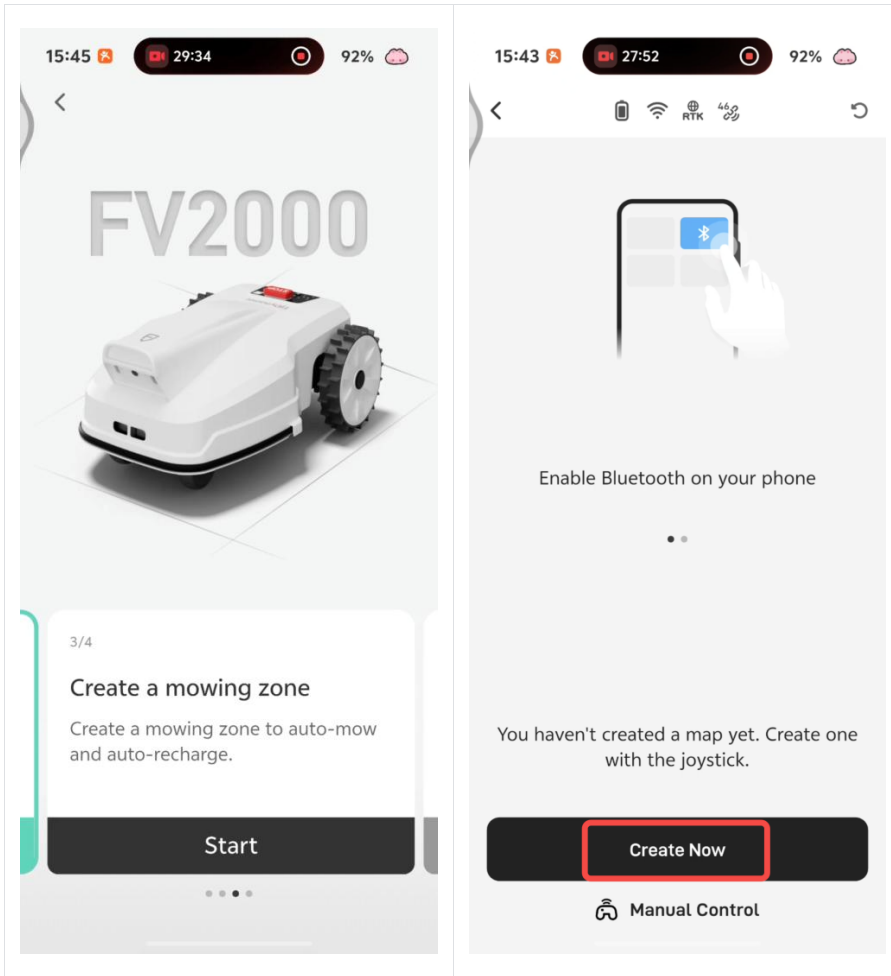

3. Click the {Turn on visual aid mapping} button to confirm the use of visual aid mapping.

### Mapping Setup

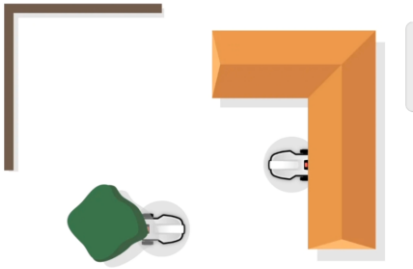

Mapping Tip: If your charging station is near obstructions (e.g., walls, houses, or trees), use Visual Assistance to guide the mower to an open area. Confirm the positioning is accurate before starting the mapping process.

Smart Mapping

Turn on visual aid mapping

Please note that the visual assistance mapping distance should not exceed 10 meters (that is, the distance between the lawn mower and the open environment with RTK fixed solution should not exceed 10 meters, otherwise the accumulated error may cause the lawn mower to be difficult to automatically return to the charging pile after completing the operation), otherwise an abnormal termination as shown in the figure may pop up. If it is abnormal, the mapping process must be restarted.

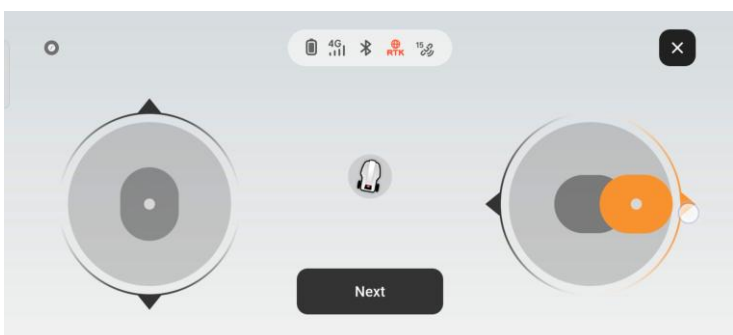
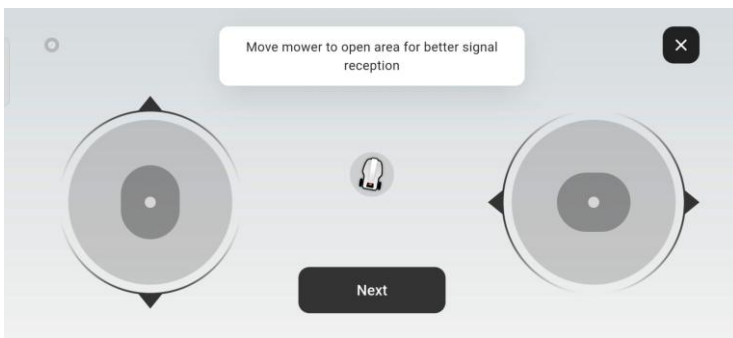



5. When the lawnmower reaches an open environment with RTK fixed solutions, a pop-up window will remind the user that they can start creating the job area as needed. Click the {Next} button to start painting the workspace boundary.

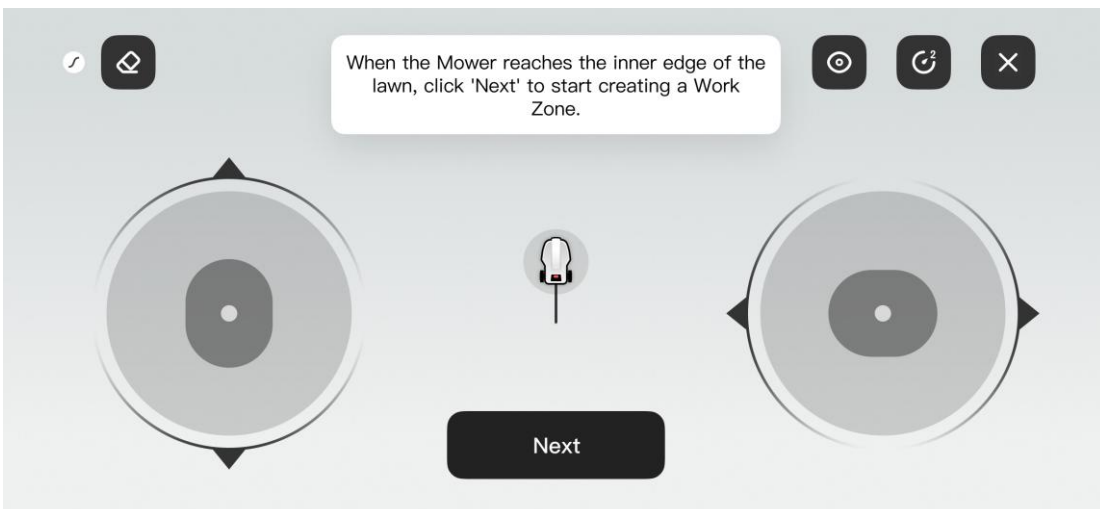
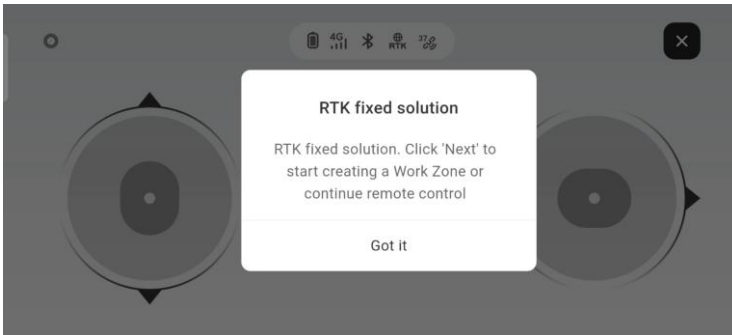

6. The subsequent establishment of the workspace and the fixed solution process with RTK are the same.

### 5.4.3.3 Prohibited area

Prohibited areas include swimming pools, flower beds, trees, roots, ditches, and any other obstacles

on the lawn. Lawn mowing robots will avoid mowing in these designated areas.

1. Confirm that the lawn mowing robot has been turned on, is on the charging pile, and is working normally. There is a fixed solution, the emergency stop button has been turned off, and the recommended battery level is above 50%.
2. Click the {New} button on the map management page.
3. Click on the prohibited area, and the lawn mowing robot can remotely draw the prohibited area through the APP.
  - a. Remote mowing robot to the edge of the expected prohibited area.
  - b. After clicking the {Start} button, operate the joystick to remotely control the lawn mowing robot to draw your lawn boundary.

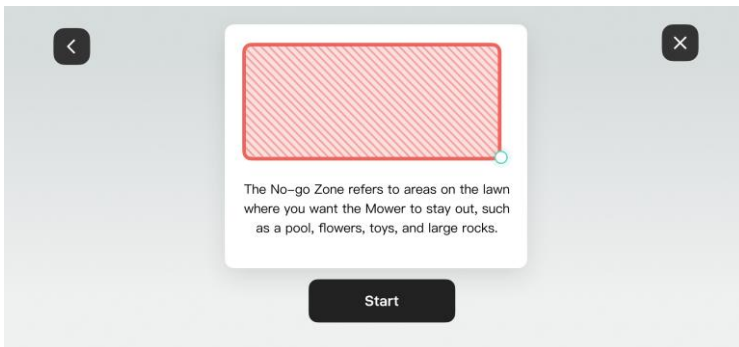

3. The solid line marks the boundary you have drawn, while the dashed line will help you return to the starting point.

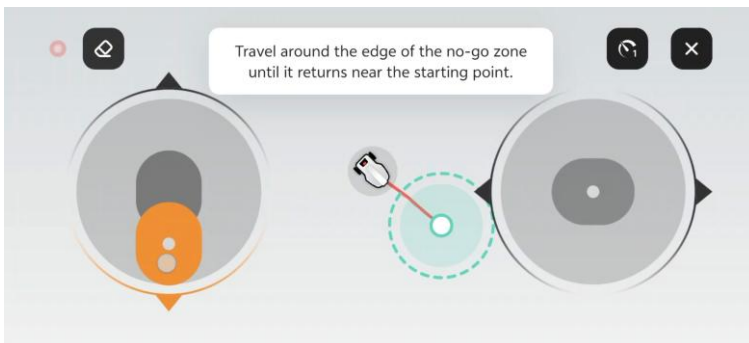

4. The forbidden area will not be created until you control the mowing robot to return to the drawing starting point.
4. If necessary, click the {erase button}, and the lawn mower robot will roll back along the already drawn path, erasing the boundary of the rolled back work area.
5. Control the mowing robot to reach the starting point and click the {Finish} button to save the prohibited area.

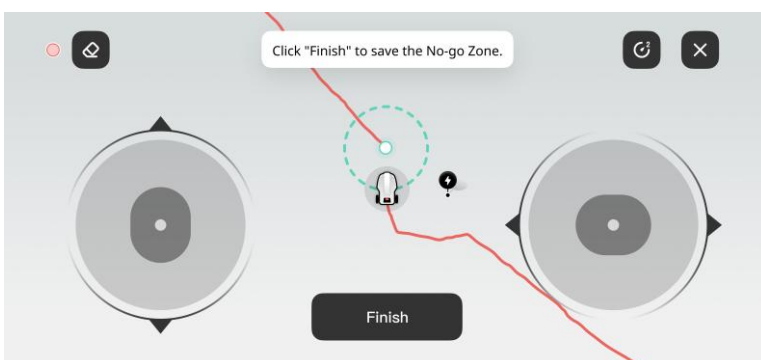

### 5.4.3.4 View the mapping area

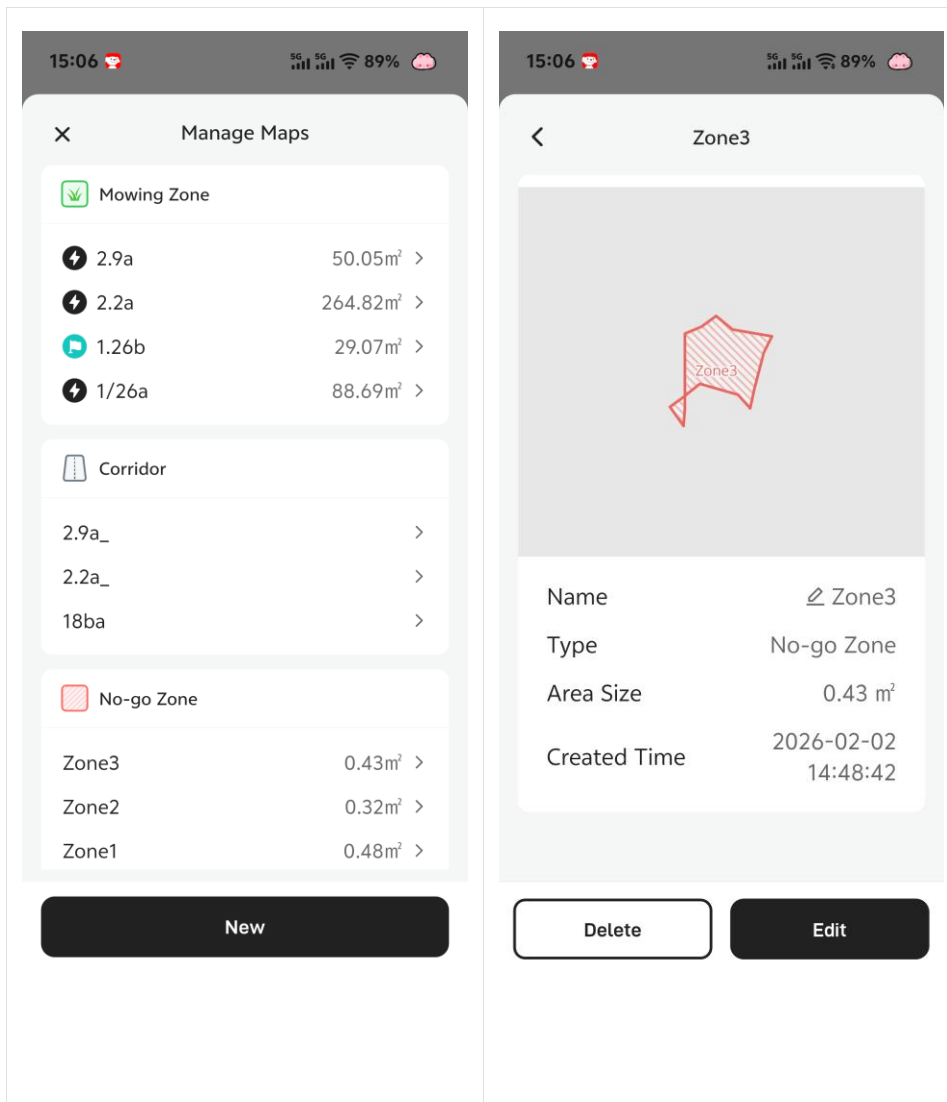

### 5.4.3.5 Delete map

- Delete a map: On the map management page, select the work area, forbidden area, and charging pile to be deleted, and click {Delete} and {OK}.
  - Warning: Deleting the charging pile will clear all saved maps of the current lawn mower robot.



## 5.5 Planned tasks

With the scheduled task function, you can set a scheduled task, and the lawn mowing robot will automatically complete its work according to your scheduled task settings.

### Note:

The planned task can only be set after the mapping is completed.

During the execution of tasks by the lawn mowing robot, modifications to the planned tasks will not affect the already executed tasks.

### 5.5.1 Add planned tasks

1. Click {Set Your Mowing Schedule} on the product homepage.

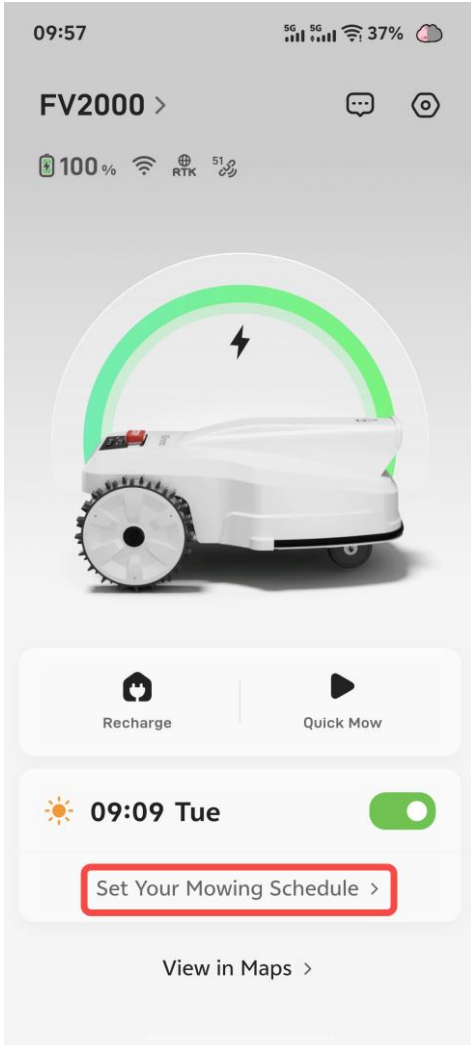

2. Press the {Add} button below to schedule the task.

9:41



Schedule

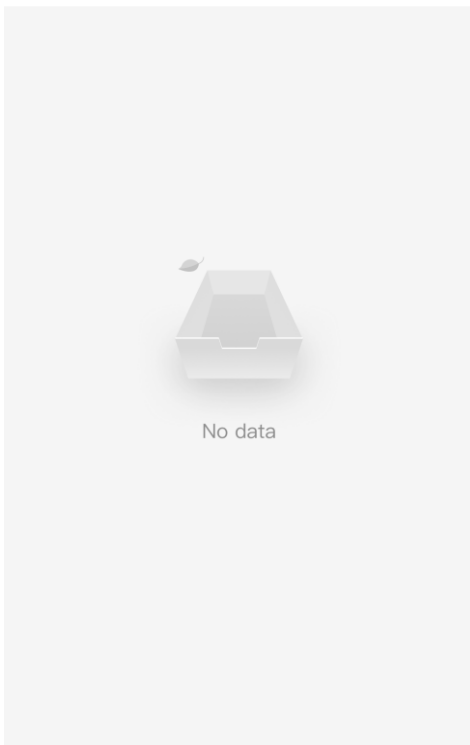

Add

3. According to the guidance of the operation interface, select and set the start time, repetition frequency, and work area of the scheduled task.

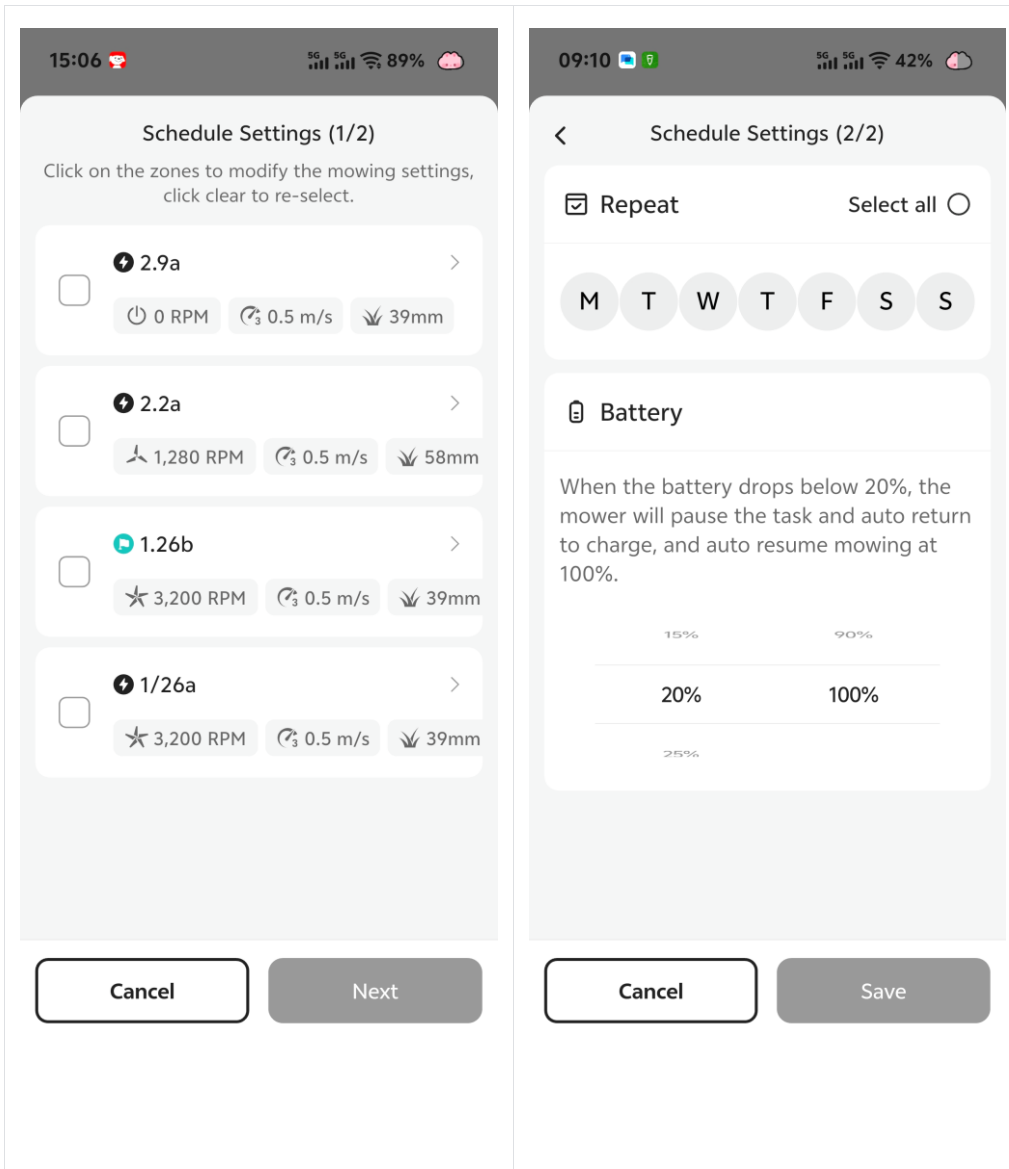

4. Individual mowing configurations can be configured for each plot, including grass height, cutter speed, movement speed, and planned path configuration. The default configuration used during mapping.

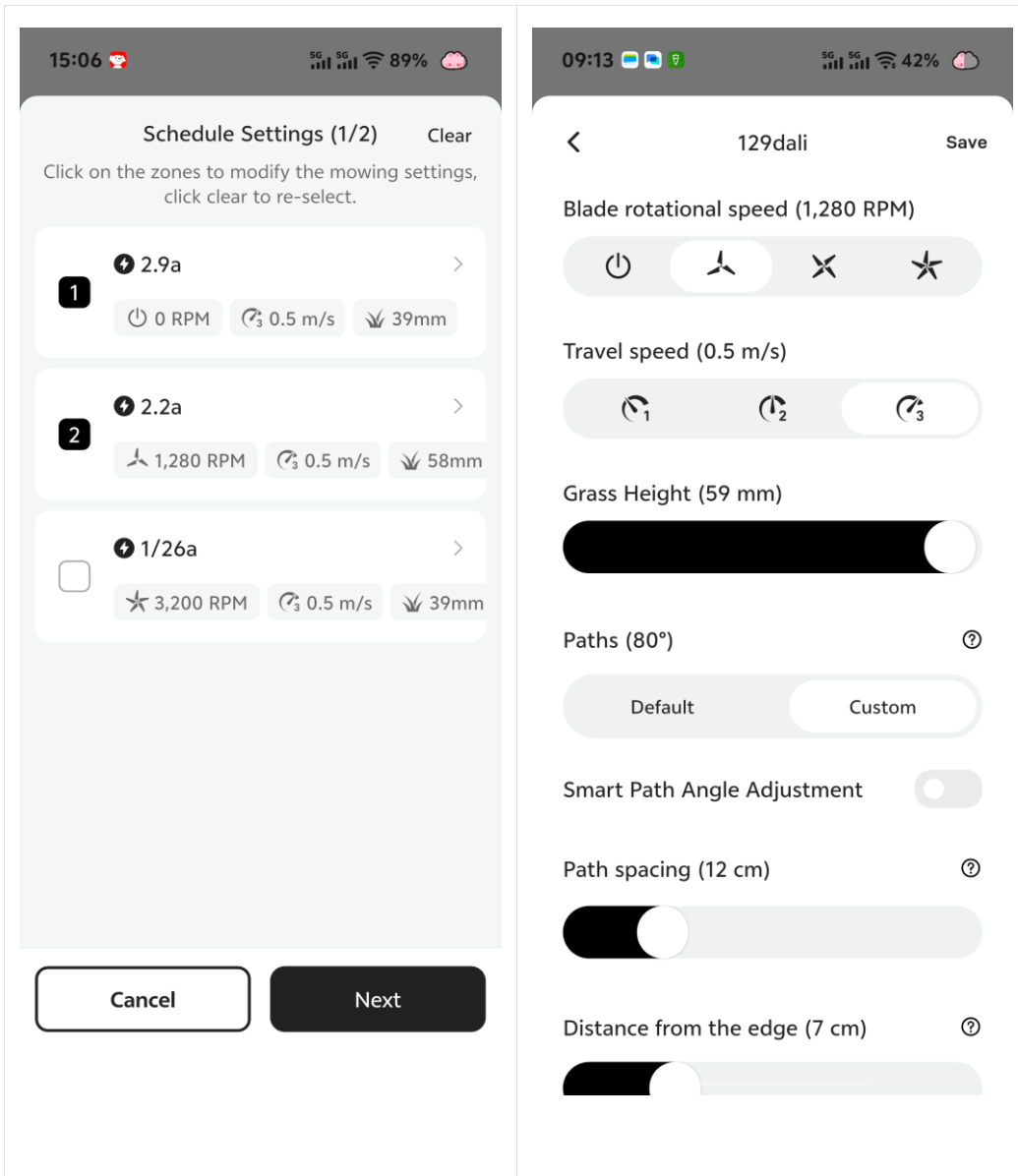

5. Click {Save button} to save the scheduled task.

## 5.5.2 Modify scheduled tasks

1. Click {Set Your Mowing Schedule} on the product homepage.

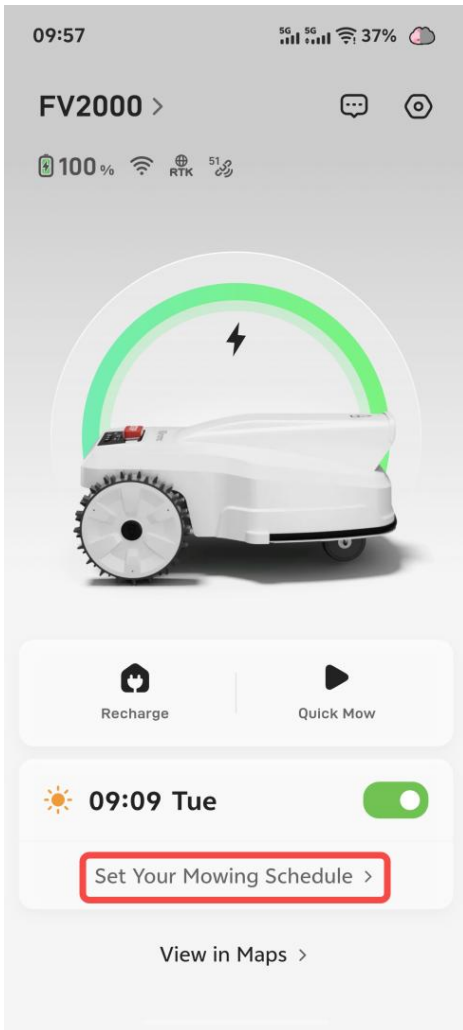

2. Click on the scheduled task item you want to modify.

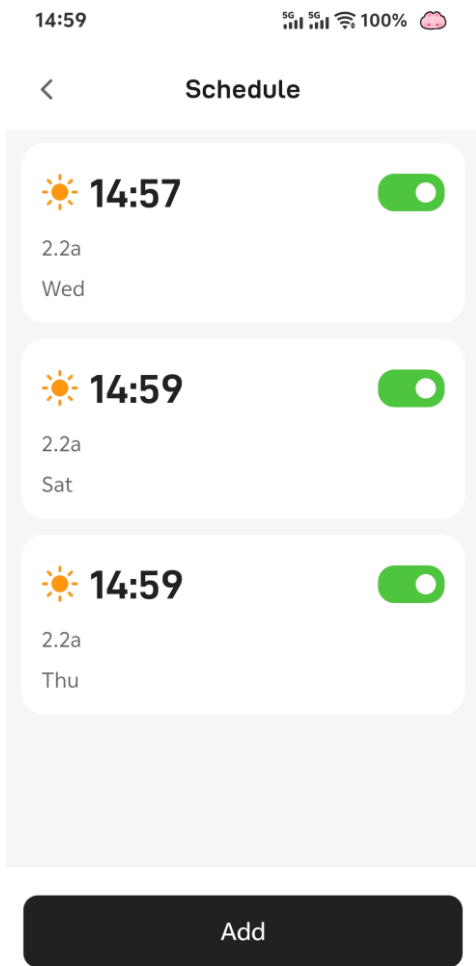

3. Modify the time, repetition frequency, work area, mowing configuration of the plot and other parameters of the planned task.
4. Click the {Save} button to save the scheduled task.

### 5.5.3 Delete scheduled tasks

1. Click {Set Your Mowing Schedule} on the product homepage.

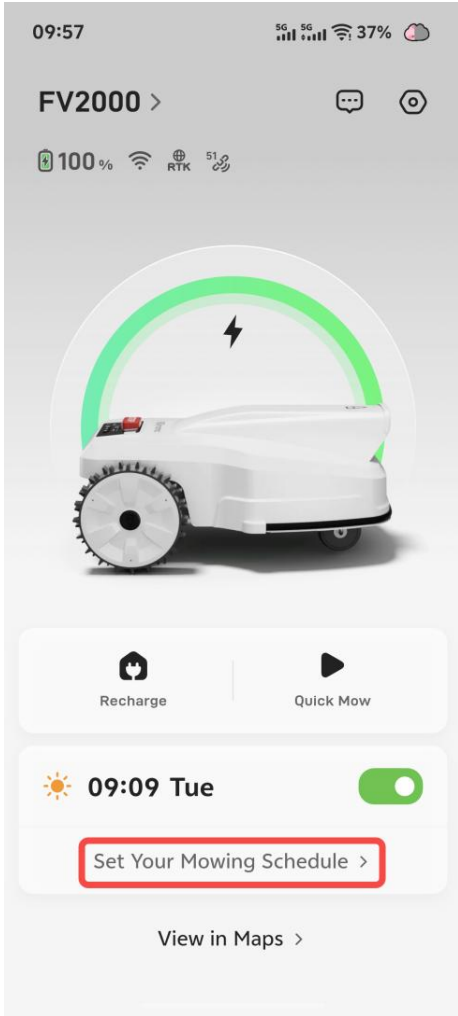

2. Swipe left on the scheduled task item you want to delete.

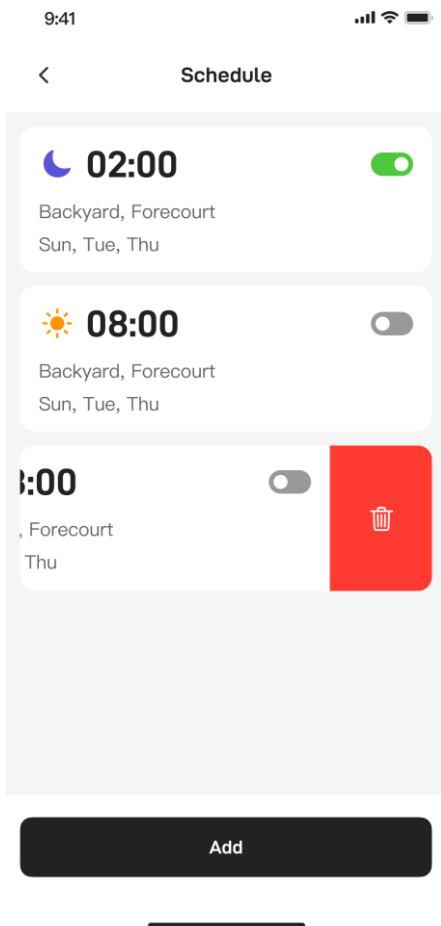

3. Click the {Delete} button that appears and confirm.

## 5.6 Manual remote control function

For your safety, there are the following precautions before using the manual remote control function:

- Children under 18 are not allowed to use this feature.
- Please take care of your children, pets, and important items at all times to prevent accidents.
- Be extra careful when using the manual remote control function to avoid injury.
- If the lawn mowing robot is performing a task, activating the manual remote control function will interrupt the task.

### 5.6.1 Manual remote control function page introduction

#### 5.6.2 Activate the manual remote control function

1. Please ensure that the Bluetooth function of your phone is turned on and that the distance between your phone and the lawn mowing robot is less than 3m.
2. Make sure the mowing robot is working properly and the emergency stop switch is turned off.
3. Click {View in Maps} on the product function homepage, then click the remote control icon.
4. The APP will activate Bluetooth connection to the lawn mowing robot, and after successful connection, it will enter the remote control page.

5. Operate the forward/backward, left/right joystick to remotely control the mowing robot.
6. Click {Speed Button} to adjust the driving speed in manual remote control mode
  - a. Note: The adjustment of this speed will not affect the speed of the mowing robot during automatic operation

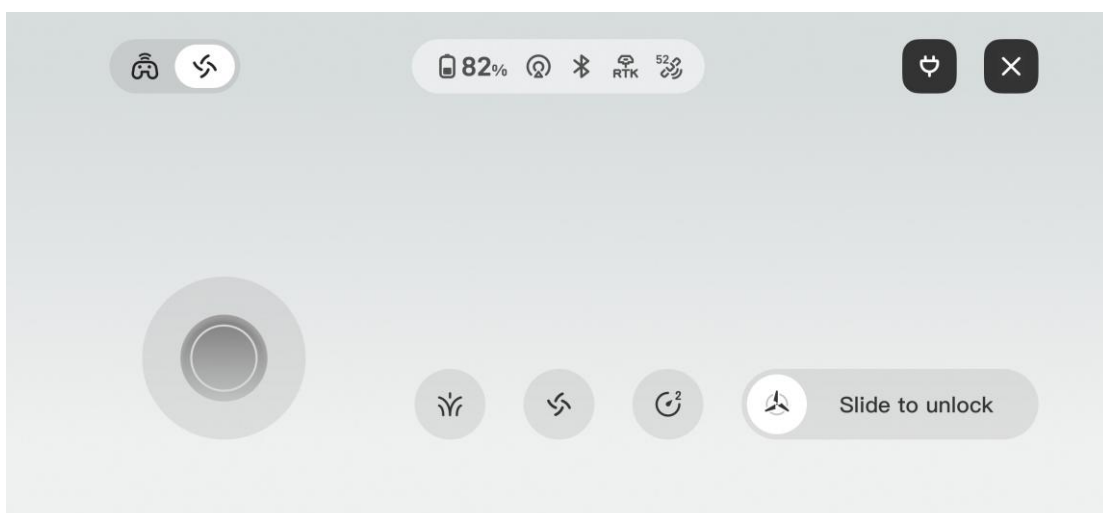
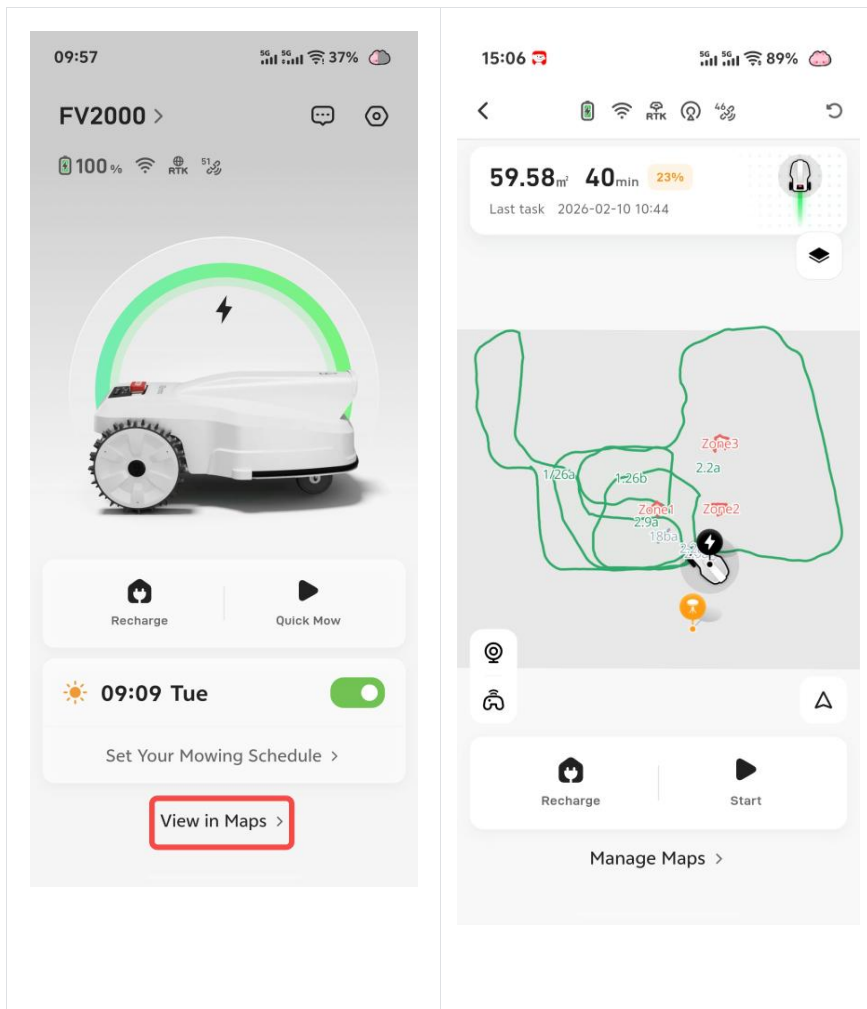

### 5.6.3 Exit manual remote control function

Click the {X button} in the upper right corner to exit the manual remote control function.

## 5.7 Mowing operation

### 5.7.1 Preparation work

Make sure the mowing robot is at the charging pile in the work area and has sufficient battery.

If there are any accidents during the mowing process, please press the emergency stop button on the mowing robot. The mowing robot will respond to the emergency stop switch first, pause the task, and turn off the cutter.

It is not recommended to mow the same lawn area more than once a day, as doing so may damage your lawn.

Our company's lawn mower supports setting the grass height to 50mm-10mm. The recommended grass height for each mowing is  $\frac{2}{3}$  of the current grass height. If the grass height is higher than 60mm/2 in, it is recommended to set the minimum grass height to 40mm/1.6 in.

### 5.7.2 Immediate operation

#### 5.7.2.1 Execute one-click jobs through APP operations

Note:

Activate the job with one click through the APP, and the lawn mowing robot will execute the mowing operation on all plots that have been mapped in the locomotive in the order of mapping.

1. Click on {Quick Mow} on the homepage of the lawn mowing robot app, and the lawn mowing robot will perform a one-click job.

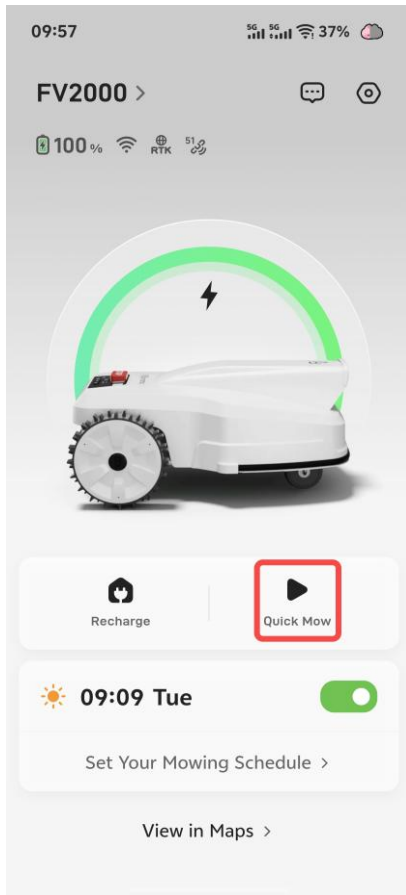

### 5.7.2.3 Execute selected jobs through APP operations

1. Click on {View in Maps} on the homepage of the lawn mowing robot app.
2. Select the work area where you want to mow the lawn.
3. Click the {Start} button, and the lawn mowing robot will perform the mowing operation in the corresponding work area.

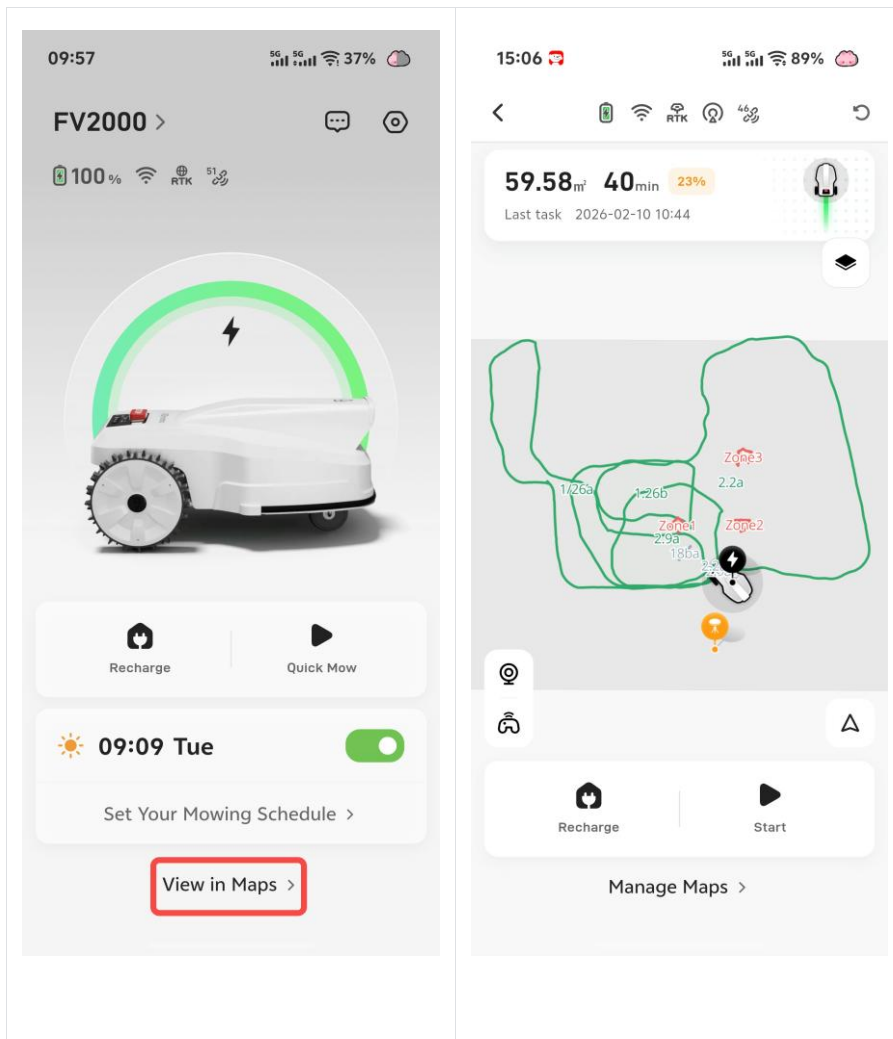

### 5.7.3 Set scheduled tasks

1. Plan execution through APP settings
  - a. Reference, add planned tasks
2. The lawn mowing robot will automatically activate the job according to your planned task settings.

### 5.7.4 Suspension/termination of operations

Press the emergency stop button on the top control panel of the lawn mower or click the pause button in the APP

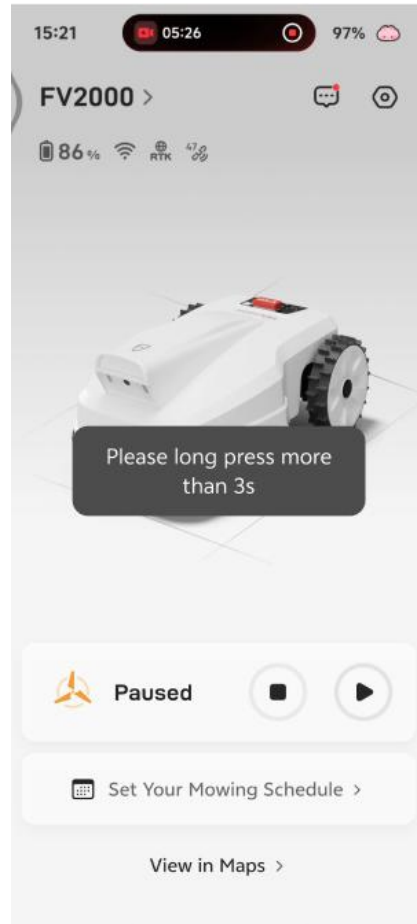
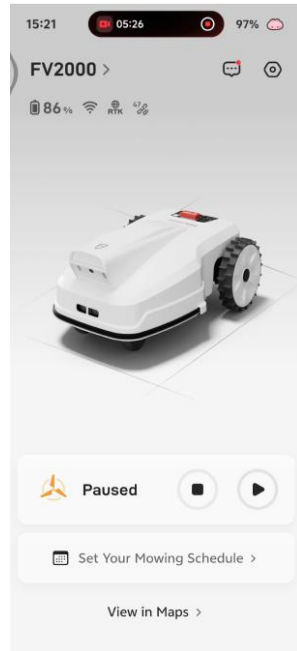
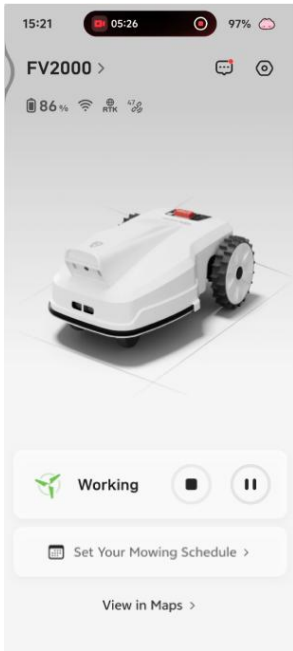

## 5.7.5 Recovery operations

Press the {Mowing button} and {Confirm button} on the top control panel of the lawn mower or click the Continue button in the APP

9:41



FV2000121FY >



82%    

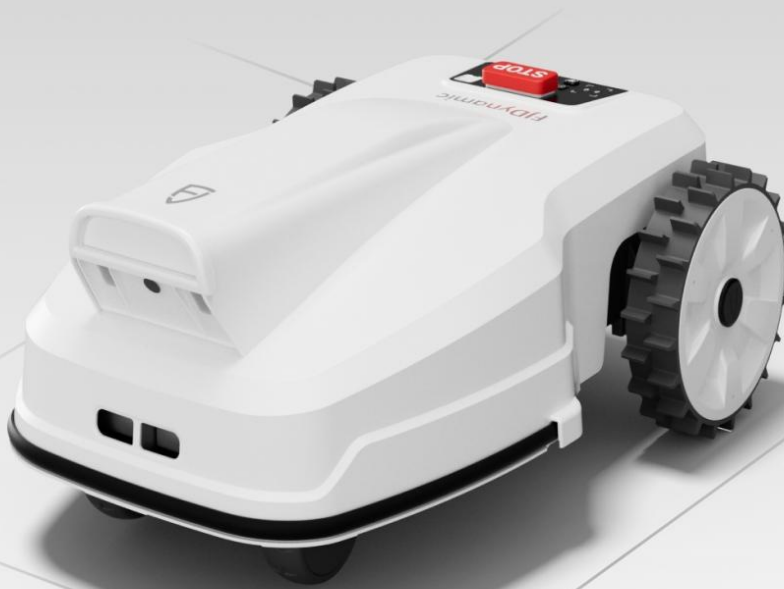

Paused



10:00 - 14:00



Set Mowing Plan >

During the mowing process, if the battery is too low (below 10%), the mower will automatically stop mowing and recharge. When the battery returns to the setting value for continuing mowing (default is 80%), the mower will automatically return to the breakpoint of the previous operation to continue mowing.

## 5.8 Recharge

### 5.8.1 Automatic recharge

Automatic charging - When the lawn mowing robot completes the mowing operation normally or triggers the breakpoint continuation condition, it will try to return to the charging pile and charge itself.

- When the recharge function is triggered, the lawn mowing robot needs to be in the already built work area and not in the restricted area.

### 5.8.2 Execute through APP operation

By issuing instructions through the APP, the lawn mower can be returned to the charging pile.

1. Click on {Recharge} on the homepage of the lawn mowing robot app.
2. Click the {OK} button.
3. The lawn mowing robot will activate the recharge function.

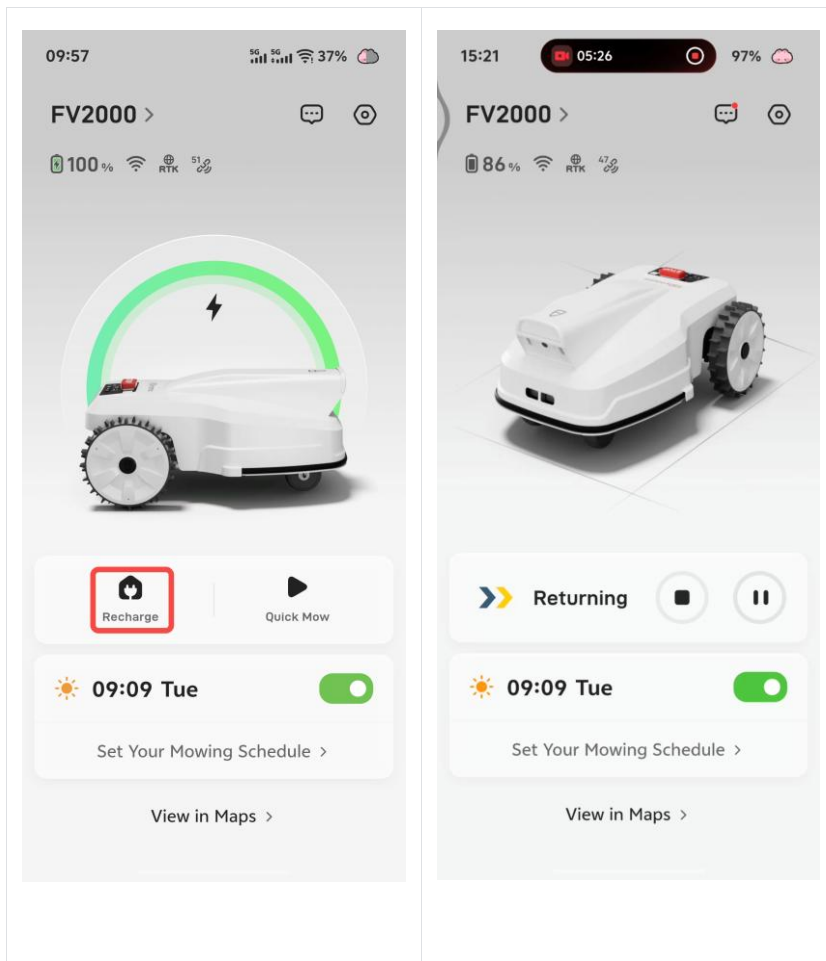

## 5.9 Continued cutting

During the mowing process, if the battery is too low (below 10%), the mower will automatically stop mowing and recharge. When the battery returns to the setting value for continuing mowing (default is 80%), the mower will automatically return to the breakpoint of the previous operation to continue mowing.

When the lawn mower returns to the charging pile due to continued cutting, it reports a status of continued cutting waiting.

Users can terminate the continuation waiting state through the {STOP button} of the APP in this state, and subsequent cutting tasks will not be able to be restored.

Users can start the continuous cutting operation instantly through the {START button} of the APP in this state, even if the power of the lawnmower has not reached the allowable value of the pile for continuous cutting.

### 5.9.1 Continuous cut configuration

Users can configure the power levels for cutting pause and resumption on the task settings page.

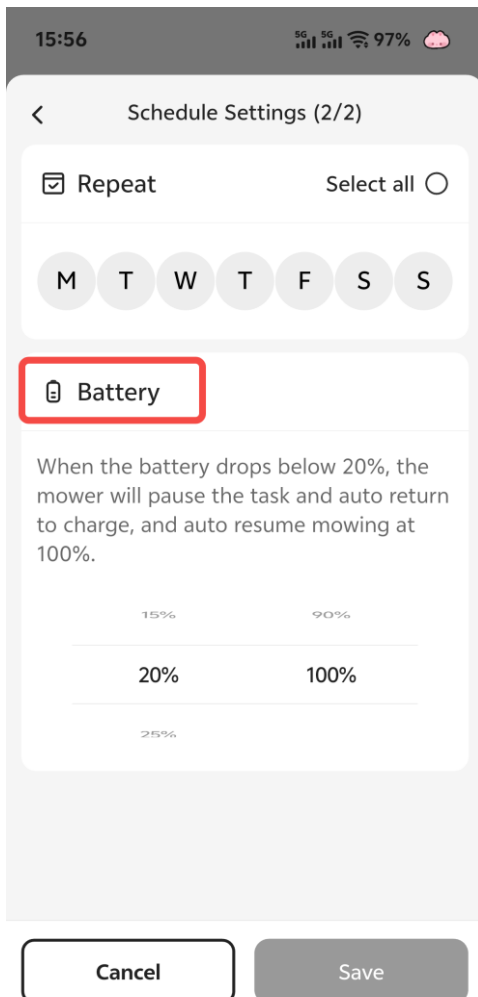

Users can enable/disable the continuation function (enabled by default).

Users can set the battery trigger value (default 80%) for the continuation and recovery job.

## 5.9.2 Manual operation

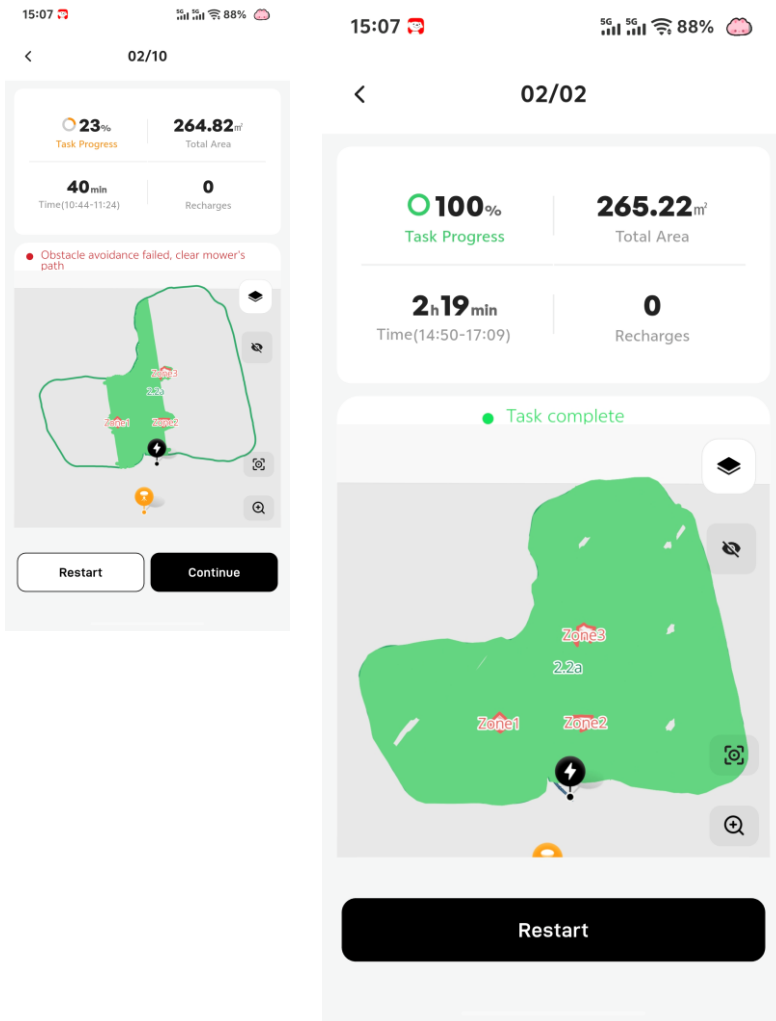

## 5.10 Message center

Information about device exception notifications, any errors, etc. will be displayed in the Message Center section. Click on Message Center for more detailed information.

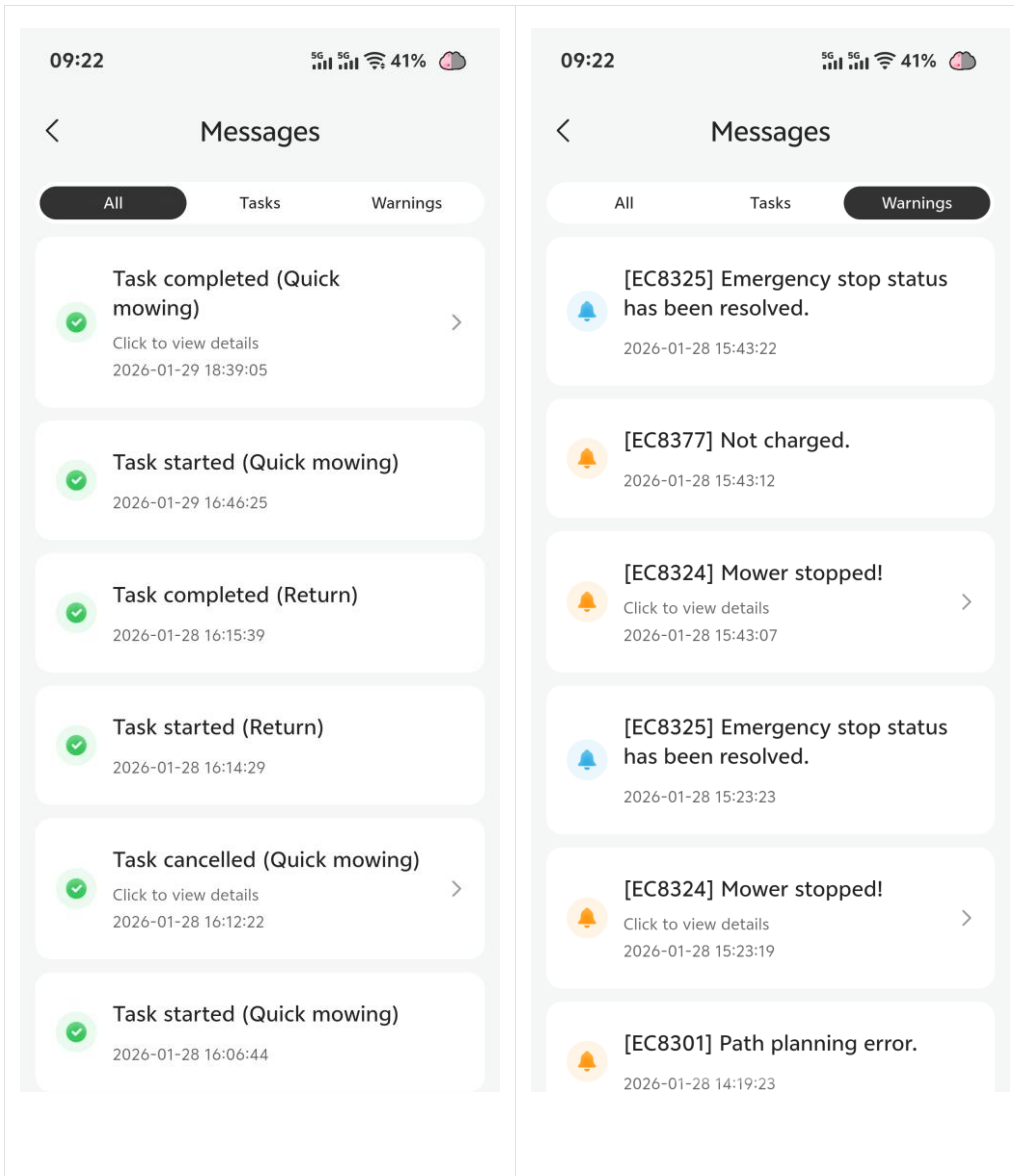

## 5.11 Settings

Click the gear icon in the upper right corner of the device to enter the settings page.

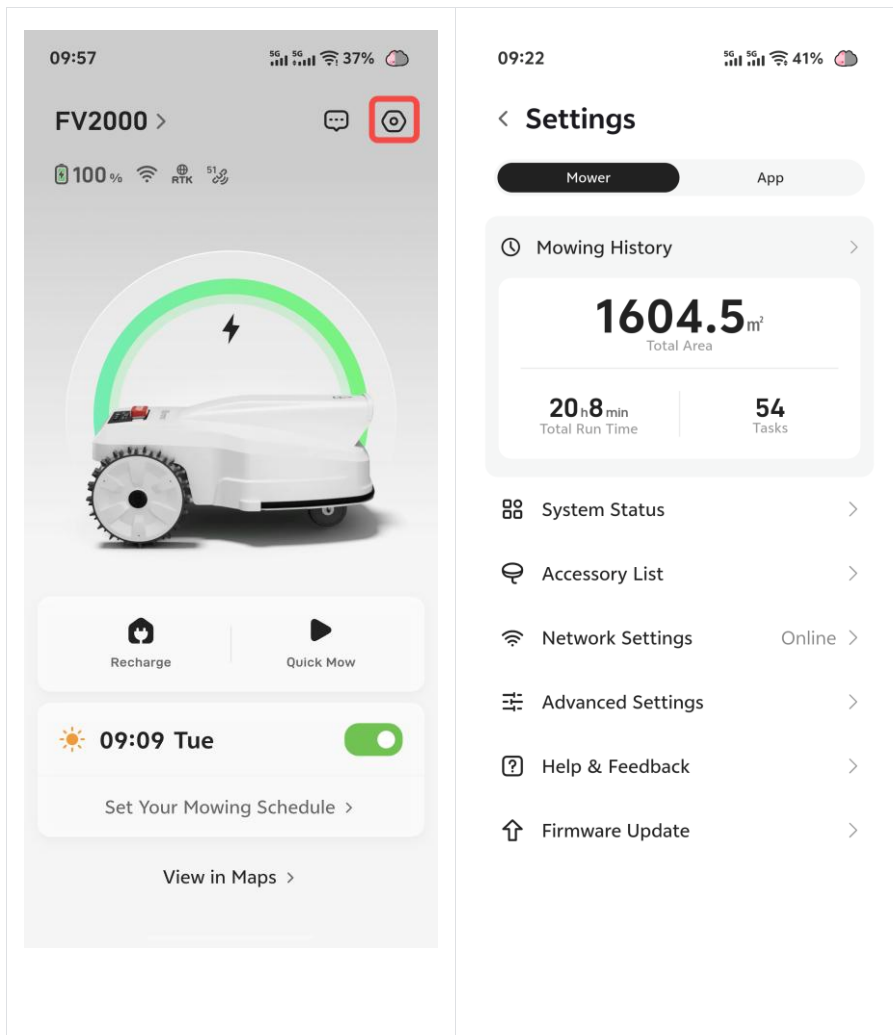

### 5.11.1 Device information

You can view information such as device type, serial number, firmware version, etc

### 5.11.2 Accessory maintenance

You can view the accessory information and details of the lawn mowing robot

### 5.11.3 Network information

You can view the network information of the lawn mowing robot

### 5.11.4 Firmware upgrade

You can check the current version and check for updated firmware versions.

When there is a new version, you can upgrade the firmware here.

1. It is recommended to upgrade when the car's battery is sufficient and there is no work within a certain period of time.
2. Ensure that the Wi-Fi signal connected to the car system is good.
3. Enter {Firmware Update} and click {Update Now}.
4. Wait for the upgrade to complete.

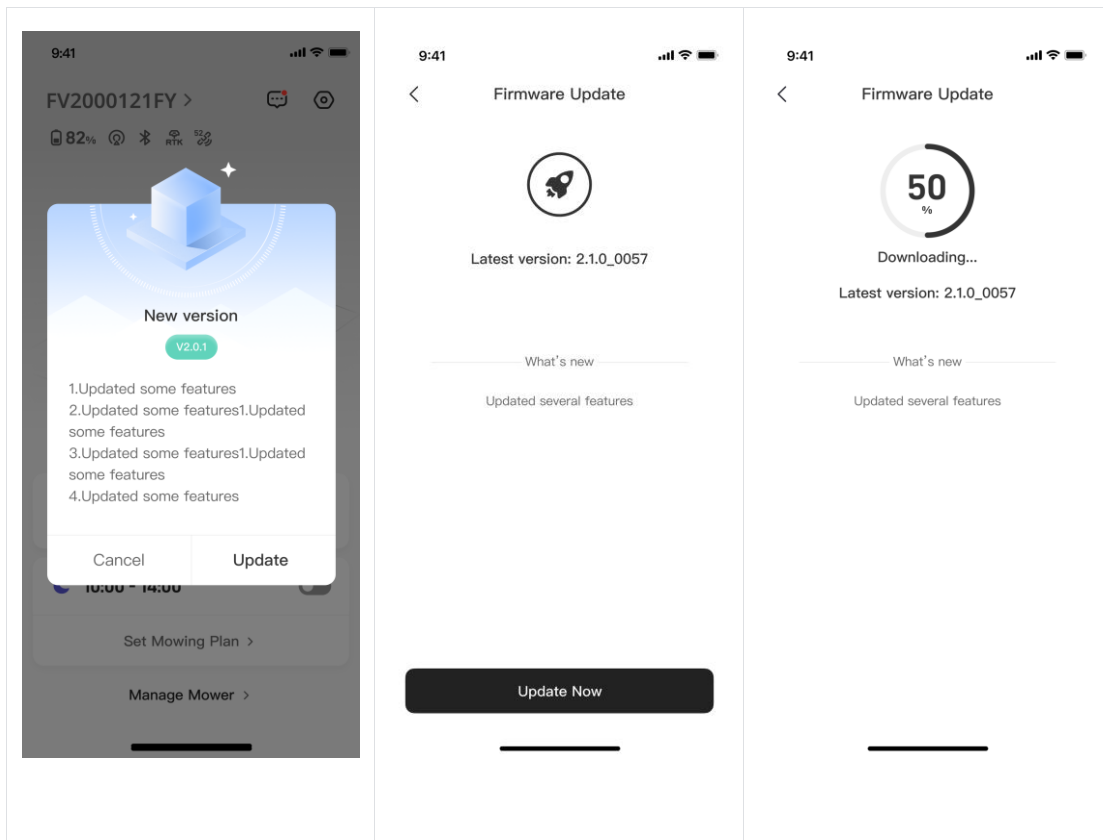

### 5.11.5 Continuous cut configuration

You can view the configuration related to the continued cutting of the mowing robot.

## 6. Maintenance

### 6.1 Notes

When using it for the first time, please choose a flat ground and trim slowly. The mowing method depends on the size and shape of the site. Please consider obstacles such as trees, fences, and buildings

The mowing method depends on the size and shape of the site. Please consider obstacles such as trees, fences, and buildings. It is recommended that the grass height be within the range of 50-80 mm (1.97-3.15 inches) before mowing. Do not trim more than 1/3 or 25 of the plant height at one time.

It is recommended that the grass height be within the range of 50-80 mm (1.97-3.15 inches) before mowing. Do not trim more than 1/3 of the plant height or more than 25 mm (0.98 inches) at a time. When the grass is high, in order to avoid the situation where the grass debris cannot be discharged well, increase the cutting height and cut multiple times to make the mowed marks look good. It is best to do the work in the afternoon or evening with less humidity.

### 6.2 Cutting table cleaning

Please always wear heavy gloves, pants, and work shoes when cleaning the

cutting table.

Please follow the operating instructions and clean the cutting table after shutdown.

Thoroughly clean the outside of the lawn mower with a soft brush or cloth. Do not clean with alcohol, gasoline, acetone, or other corrosive/volatile solvents. These substances may damage the appearance and internal structure of the lawn mower.

## **Chassis and blade disc**

If the chassis and blade disc are dirty, please clean them with a brush or water pipe. Do not use a high-pressure washer. At the same time, make sure that the blade disc rotates freely and the blades can rotate freely.

Note: High-pressure water may penetrate seals and damage electronic and mechanical components

## **Blade fender**

Regularly inspect the blade fender. If mud, grass clippings, or other objects accumulate on the blade fender, remove them with a dry brush or scraper.

## **Cutting table grass treatment**

When you suspect that the grass is stuck inside the cutting table, you can use the lifting function of the cutting table to check and clean it.

1. Keep the lawn mower turned on, open the mobile app, enter {Settings}, {Accessory Lists}, {Blade Disc}, and click the {Blocked with Grass?} button.
2. After the Bluetooth connection is successful, the cut disk will extend outward to the maximum.
3. After the extension is completed, please turn off the power of the lawnmower and lift the body of the lawnmower to check if the cutting disc is stuck
4. After processing, put down the lawnmower, turn it on, and the cutting disc will automatically return to its initial state.

Note: Please always wear heavy gloves, pants, and work shoes when cleaning the cutting table.

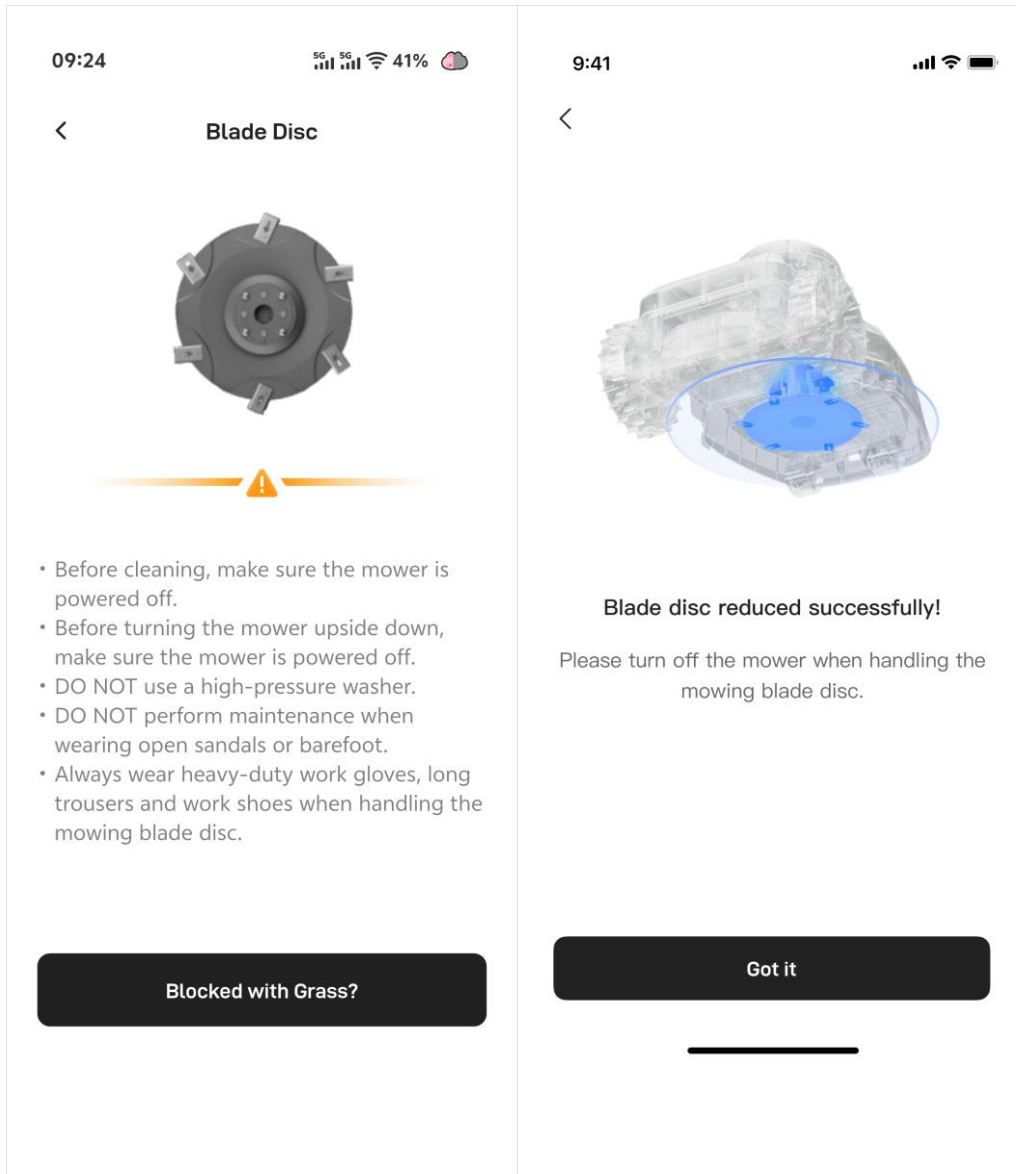

## Blade replacement

Remove the blade by unscrewing the illustrated screwdriver with an internal hexagon wrench and replace it as needed.

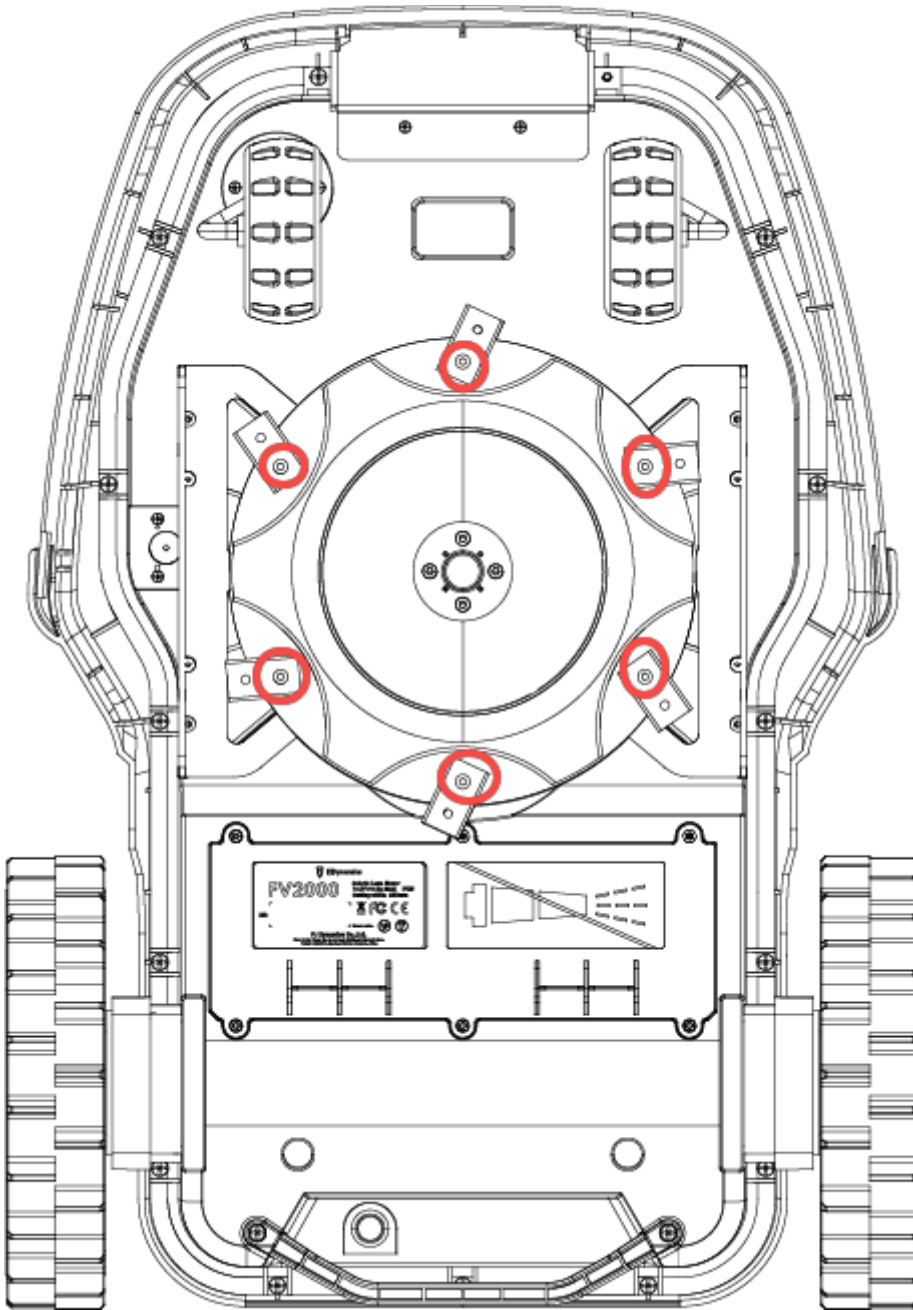

### 6.3 Slope reference

The FV2000 can be used for mowing on slopes up to 33 degrees.



## 7. Troubleshooting

The application will display common device failures.

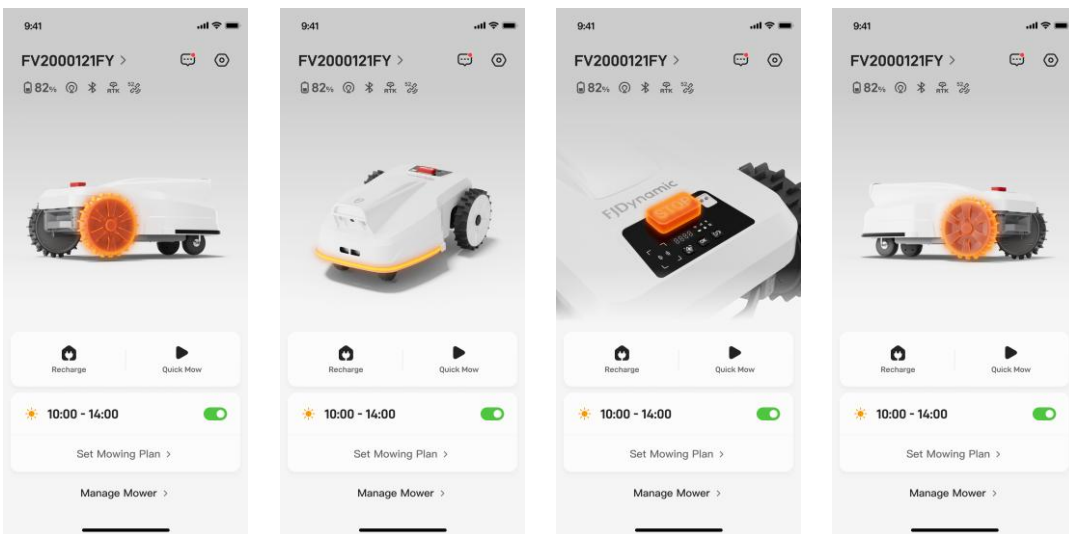

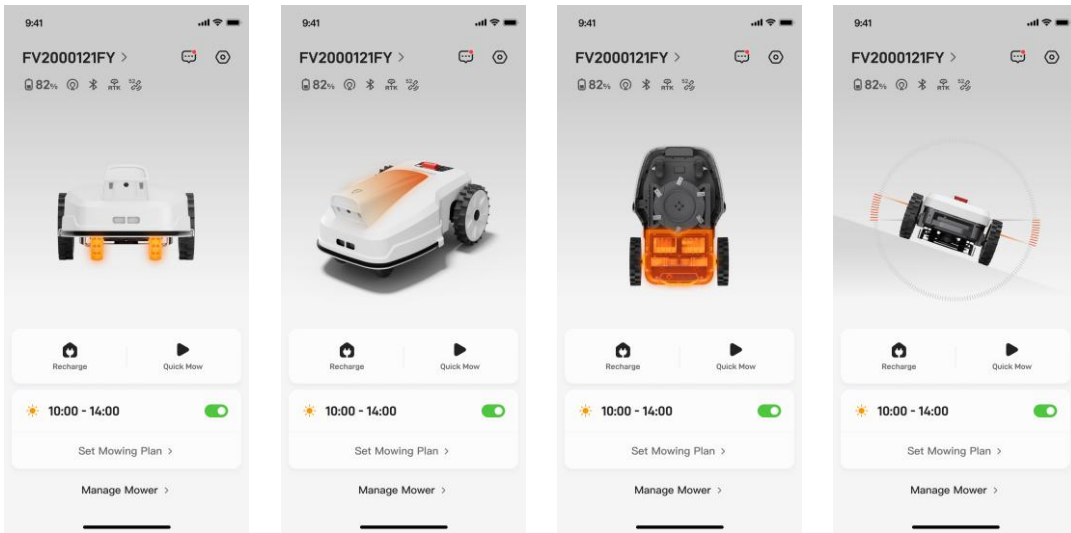

## 8. Warranty Policy

FJDynamics guarantees that this product is free from material and workmanship defects during the warranty period according to the product information under normal use. Published product information includes but is not limited to user manuals, quick start guides, maintenance, specifications, disclaimers, in-app notifications, etc. The warranty period varies depending on the product and components. Please refer to the table below.

| Component             | Warranty    |
|-----------------------|-------------|
| Lawn mower body       | 2 years     |
| Battery               | 2 years     |
| Charging piles        | 1 year      |
| Tires                 | No warranty |
| Decoration/Appearance | No warranty |
| Cutting blade         | No warranty |

Tires, trim/appearance, and cutting blades are vulnerable parts and are not covered by the warranty.

If the product cannot be used normally during the warranty period, please contact the FJDynamics Client Server department for guidance. Please provide the receipt and Serial Number when contacting customer service.

- The warranty period for this product is calculated from the date of delivery.
- If you cannot provide an invoice or other valid proof of purchase, the warranty period will begin 90

days after the production date displayed on the product, unless otherwise agreed between you and FJDynamics.

- If the user wishes to send the product to the local service center or FJDynamics factory for further diagnosis, the user needs to arrange for shipment themselves. If the problem is within the warranty period, FJDynamics will repair or replace it for free and return it to the user. If not, FJDynamics or the designated service center may charge corresponding fees.

## 9. Important information

### **America's Federal Communications Commission (FCC)**

#### FCC Statement

This device complies with Part 15 of the FCC Rules. Operation is subject to the following two conditions: (1) This device may not cause harmful interference, and (2) this device must accept any interference received, including interference that may cause undesired operation.